

*Tesis Doctoral*

*Biociencias: Biología y Clínica del Cáncer y Medicina Traslacional*

*Instituto de Biología Funcional y Genómica*

**Camilla Frattini**

***The Bul2/Rsp5 ubiquitin ligase complex  
promotes cohesin-mediated fork re-start***

**Dr. Rodrigo Bermejo Moreno**, científico titular del Consejo Superior de Investigaciones Científicas (CSIC)

**CERTIFICA:**

Que la licenciada **Camilla Frattini** ha realizado el trabajo titulado "**Bul2/Rsp5 ubiquitin ligase complex promotes cohesin-mediated fork re-start**", bajo mi dirección, en el Instituto de Biología Funcional y Genómica, centro mixto de la Universidad de Salamanca (Departamento de Microbiología y Genética) y del Consejo Superior de Investigaciones Científicas (CSIC), para optar al grado de Doctor en Biología.

Y para autorizar su presentación y evaluación por el tribunal correspondiente, expide el presente certificado en Salamanca, a 8 de Julio de 2016.



Rodrigo Bermejo Moreno

**Director de la Tesis Doctoral**



VNIVERSIDAD  
D SALAMANCA

ESTADÍSTICA DE PROFESIONALES INTERDISCIPLINARIOS



CENTRO DE INVESTIGACIÓN  
DEL CÁNCER

**Dr. María de la Paz Sacristán Martín**, profesora titular en el Departamento de Microbiología y Genética de la Universidad de Salamanca

**CERTIFICA:**

Que la licenciada **Camilla Frattini** ha realizado el trabajo titulado "**Bul2/Rsp5 ubiquitin ligase complex promotes cohesin-mediated fork re-start**", bajo mi tutoría y en el programa de Doctorado de Biociencias: Biología y Clínica del Cáncer y Medicina Traslacional.

Y para autorizar su presentación y evaluación por el tribunal correspondiente, expide el presente certificado en Salamanca, a 8 de Julio de 2016.

  
María de la Paz Sacristán Martín

**Tutora de la Tesis Doctoral**



# Table of contents

|  |           |
|--|-----------|
| <b>ABSTRACT</b>  | <b>11</b> |
| <b>RESUMEN</b>   | <b>13</b> |
| <br>   |           |
| <b>1 INTRODUCTION / INTRODUCCIÓN</b>   | <b>17</b> |
| 1.1 General aspects of <i>S.cerevisiae</i> cell cycle checkpoints.                         | 17        |
| 1.2 DNA replication and the DNA replication checkpoint.                                    | 19        |
| DNA replication.   | 19        |
| The DNA replication checkpoint.  | 25        |
| 1.3 DNA replication and cohesin.   | 27        |
| Cohesin loading.   | 30        |
| Cohesin establishment.   | 30        |
| Cohesin release.   | 31        |
| 1.4 DNA replication and ubiquitination.  | 32        |
| 1.5 Rsp5/Bul2 ubiquitin ligase complex.  | 35        |
| <br>   |           |
| <b>2 OBJECTIVES / OBJETIVOS</b>  | <b>41</b> |
| <br>   |           |
| <b>3 RESULTS / RESULTADOS</b>  | <b>43</b> |
| 3.1 The Bul2/Rsp5 complex is involved in the cellular response to replication stress.      | 43        |
| 3.1.1 Bul2/Rsp5-mediated ubiquitylation events are required to survive replication stress. | 43        |
| 3.1.2 Bul2/Rsp5 is required for efficient chromosome duplication in the presence of HU.    | 45        |
| 3.1.3 Bul2/Rsp5 is involved in the re-start of stalled replication forks.                  | 47        |
| 3.1.4 Bul2/Rsp5 promotes replication fork stability.                                       | 51        |
| 3.2 The Bul2/Rsp5 complex is recruited to replication forks.                               | 52        |
| 3.2.1 Bul2/Rsp5 and Mec1/Ddc2 complexes interact during S-phase.                           | 53        |
| 3.2.2 Investigating crosstalk between Bul2/Rsp5 and Mec1/Ddc2 complexes.                   | 56        |
| 3.2.3 The Bul2/Rsp5 complex is recruited to stalled replication forks.                     | 60        |
| 3.3 The Bul2/Rsp5 complex promotes cohesin-mediated replication fork re-start.             | 62        |
| 3.3.1 Bul2/Rsp5 physically interacts with cohesin subunits Smc1 and Smc3.                  | 62        |
| 3.3.2 Cohesin complex is required for the re-start of replication forks                    | 63        |

stalled by dNTP pools depletion.

3.3.3 Bul2/Rsp5 stimulates cohesin function in replication fork re-start. 69

|          |  |            |
|----------|--|------------|
| <b>4</b> | <b>DISCUSSION / DISCUSIÓN</b>                            | <b>75</b>  |
| <b>5</b> | <b>CONCLUSIONS / CONCLUSIONES</b>                        | <b>85</b>  |
| <b>6</b> | <b>MATERIALS &amp; METHODS / MATERIALES Y MÉTODOS</b>    | <b>87</b>  |
| 6.1      | Strains and plasmids.                                    | 87         |
| 6.2      | Growing media for <i>Saccharomyces cerevisiae</i> cells. | 90         |
| 6.3      | List of buffers.   | 92         |
| 6.4      | PCR.   | 94         |
| 6.5      | High efficiency LiAC transformation.                     | 97         |
| 6.6      | Colony PCR.  | 98         |
| 6.7      | Growth conditions, cell cycle arrest and HU treatment.   | 99         |
| 6.8      | Serial dilutions and spot assay.                         | 100        |
| 6.9      | TCA protein extraction.                                  | 100        |
| 6.10     | SDS-PAGE and Western Blot analysis.                      | 100        |
| 6.11     | FACS analysis.   | 102        |
| 6.12     | Co-immunoprecipitation assay.                            | 103        |
| 6.13     | Neutral/Neutral 2D gel electrophoresis analysis.         | 104        |
| 6.14     | Chromatin immunoprecipitation (ChIP).                    | 110        |
| 6.15     | Sister Chromatid Exchange assay (SCE).                   | 117        |
| 6.16     | Ni-NTA affinity chromatography (His-Pull Down).          | 119        |
|          | <b>BIBLIOGRAPHY / BIBLIOGRAFÍA</b>                       | <b>123</b> |

# Figure index

Figure 1.1. DNA damage checkpoints.

Figure 1.2. Model for eukaryotic helicase activation and replisome assembly.

Figure 1.3. Schematic representation of the replisome at replication forks.

Figure 1.4. Checkpoint activation in response to replication stress.

Figure 1.5. Cohesin structure.

Figure 1.6. The chromosome cohesion cycle.

Figure 1.7. The ubiquitylation cascade.

Figure 1.8. Classes of E3 ubiquitin-ligase enzymes.

Figure 1.9. *S. cerevisiae* Nedd4-like Rsp5 ubiquitin ligase.

Figure 1.10. Model of Rsp5/Bul2 mediated regulation of substrates.

Figure 3.1. HU sensitivity of Rsp5/Bul1-Bul2 ubiquitin ligase complex mutants.

Figure 3.2. *BUL1 BUL2* double deletions delay cell cycle progression upon replication stress induction by HU treatment.

Figure 3.3. Replication intermediates of WT and *bul1Δ bul2Δ* cells upon replication stress induction by HU treatment.

Figure 3.4. Deletion of *BUL1* and *BUL2* impairs stalled replication fork progression.

Figure 3.5. Analysis of sister chromatid recombination rates in WT and *bul1Δ bul2Δ* cells.

Figure 3.6. The Bul2/Rsp5 complex interacts with Mec1-Ddc2 in HU-treated cells.

Figure 3.7. Bul2/Rsp5 and Mec1/Ddc2 interact in S-phase cells.

Figure 3.8. Bul2/Rsp5 and Mec1/Ddc2 interact in a checkpoint-independent manner.

Figure 3.9. Ni-pull down ubiquitylation assays of Ddc2 in HU treated cells.

Figure 3.10. Phos-tag gel analysis of Rsp5 and Bul2 phosphorylation.

Figure 3.11. Bul2 colocalizes with Ddc2 at stalled replication forks.

Figure 3.12. Bul2/Rsp5 interacts with the Smc3 and Smc1 subunits of the cohesin complex.

Figure 3.13. *smc1-259* mutation delays S-phase progression upon HU-induced replication stress.

Figure 3.14. 2D gel analysis of stalled fork progression in WT and *smc1-259* cells.

Figure 3.15. *smc3-42* mutants show defects in replication fork progression.

Figure 3.16. FACS profiles analysis of *smc1-259 bul1Δ bul2Δ* cells upon HU-induced replication stress.

Figure 3.17. 2D gel analysis of stalled fork progression in WT, *bul1Δ bul2Δ*, *smc1-259* and *bul1Δ bul2Δ smc1-259* cells.

Figure 4.1. Mec1/Ddc2 drive Bul2/rsp5 activity to stalled replication forks.

Figure 4.2. Bul2/Rsp5 ubiquitin ligase complex promotes cohesion-mediated for re-start.

Figure 6.1. Schematic representation of the acrylamide-pendant Phos-tag ligand and the phosphate-affinity basket.

Figure 6.2. Schematic representation of the replication intermediates detectable by 2D gel analysis.

Figure 6.3. Schematic representation of the second dimension preparation.

Figure 6.4. Schematic representation of ARS305 probes.

Figure 6.5. Schematic representation of SCE recombination substrate and gene conversion product.

Figure 6.5. Schematic representation of the principles of a <sup>His</sup>Ubiquitin Pull Down.

## Table index

Table 6.1: Genotype of strains generated and used in this study

Table 6.2: Plasmids used in this study

Table 6.3: Plasmids used for PCR

Table 6.4: Oligos used to amplify DNA probes for ARS305 (ChrIII 36958- 38041) analysis





# ABSTRACT

A complete and accurate replication of DNA is essential to maintain genome integrity. In response to replication stress cells have evolved a specialized branch of the DNA damage checkpoint response, called DNA replication checkpoint, that senses replication fork stalling and orchestrates a response aimed at delaying cell cycle progression, stabilizing fragile replication structures and promoting DNA repair.

A genome-wide genetic screen carried out in *S. cerevisiae* to discover factors mediating fork stability identified *BUL2*, coding for the adaptor of the Bul2/Rsp5 ubiquitin ligase complex. We found that *bul2* and *rsp5* mutants are sensitive to replication stress induced by hydroxyurea (HU) and that *bul2* sensitivity is suppressed by the ablation of the Ubp2 ubiquitin protease, which removes Rsp5-dependent ubiquitin chains. 2D gel and whole genome sequencing analyses revealed that cells impaired in Bul2/Rsp5 function were defective in fork re-start and progression upon HU treatment. A Mass Spectrometric analysis of Bul2 physical interactors identified Mec1, a key apical checkpoint kinase that acts as a replication stress sensor through recruitment to stalled replication forks via its partner Ddc2. Our data pointed out that this interaction is fundamental to drive Bul2/Rsp5 activity to stalled replication forks. Among Bul2 physical interactors we also scored Smc1 and Smc3 cohesin subunits. We identified a genome wide defect in cohesin mutants in re-starting replication forks upon HU treatment, which was epistatic to the defects conferred by *BUL1 BUL2* double deletion. Moreover, cohesin mutants' sensitivity to HU was suppressed by deletion of *UBP2*, pointing at a role of Bul2/Rsp5-mediated ubiquitylation events in promoting cohesin function to survive to replication stress.

We propose that Bul2/Rsp5, through interaction with Mec1/Ddc2, is directed to stalled replication where it mediates cohesin ubiquitylation in turn required to promote stalled fork stabilization and restart.



## RESUMEN

En el presente proyecto de Tesis doctoral, se aplicaron técnicas genéticas, genómicas, de biología molecular y proteómica para caracterizar el papel desempeñado por Bul2/Rsp5 en la respuesta celular a estreses genotóxicos.

Se demostró que mutantes en los genes *BUL2* (*bul2Δ*) y *RSP5* (*rsp5-1* y *rsp2-25*) son sensibles a estrés replicativo inducido por tratamiento con hidroximetilurea (HU). La delección de Ubp2, ubiquitin proteasa que elimina cadenas de ubiquitina dependientes de Rsp5, suprime la sensibilidad de células *bul2Δ* a altas dosis de HU. Análisis de los intermedios de replicación mediante geles bidimensionales de ADN (2D) en mutantes de delección *bul1Δ bul2Δ* identificaron defectos en la reiniciación de horquillas de replicación paradas mediante tratamiento con 200mM HU. Utilizando la secuenciación masiva se pudo constatar que el defecto en reinicio y progresión de horquillas de replicación era característica común a lo largo del genoma. Estos resultados indican que eventos de ubiquitinación dependientes del complejo Bul2/Rsp5 son esenciales para reiniciar horquillas de replicación y así sobrevivir a estrés replicativo. Una análisis de espectrometría de masas (MS) realizada en el laboratorio identificó entre los interactores físicos de Bul2 el complejo Mec1/Ddc2 y las subunidades Smc1 y Smc3 del complejo cohesina. Mec1 es la quinasa apical de la respuesta del *checkpoint* y actúa como sensor de estrés replicativo a través de su reclutamiento a nivel de horquillas paradas por parte del adaptador Ddc2. Demostramos que la interacción de los complejos Bul2/Rsp5 y Mec1/Ddc2 estaba incrementada en células tratadas con HU y resultó independiente de la actividad quinasa de Mec1. Explorando el significado funcional de la interacción entre los dos complejos, ensayos de *Pull Down* en células expuestas a estrés replicativo no permitieron identificar formas ubiquitinadas de Ddc2 dependientes del complejo Bul2/Rsp5. Igualmente, mediante geles Phos-tag de proteínas, se observaron formas fosforiladas de Bul2 y Rsp5; si bien estos eventos post-traduccionales no requerían la actividad quinasa de Mec1. La análisis mediante inmunoprecipitación de cromatina seguida de hibridación de arrays genómicos (ChIP-chip) de las regiones de unión de Bul2 al ADN en células tratadas con HU identificó una correlación entre las regiones cromosómicas de Bul2 y Ddc2, sugiriendo que la

interacción con el complejo Mec1/Ddc2 dirige la actividad de Bul2/Rsp5 a las horquillas de replicación paradas.

Entre los interactores físicos de Bul2 identificados por espectrometría de masas encontramos también las subunidades Smc1 y Smc3 del complejo cohesina. La función principal de cohesina en el ciclo de duplicación del genoma es la unión de cromatidas hermanas. Esta unión se establece a lo largo de la fase S de replicación de ADN y es destruida en el momento de la separación de las cromatidas en anafase durante mitosis. Demostramos, mediante ensayos de co-immunoprecipitación, la interacción entre el complejo ubiquitín ligasa Bul2/Rsp5 y las subunidades Smc1 y Smc3 en células tratadas con HU. Además observamos que mutantes en cohesina (*smc1-259*) acumulaban defectos en el reinicio y en la progresión de horquillas en presencia de estrés replicativo. Analizando el significado biológico de la interacción entre cohesina y Bul2/Rsp5, el grupo de investigación evidenció, mediante ensayos de *Pull Down* en células tratadas con HU, eventos de ubiquitinación de las subunidades Smc1, Smc3 y Scc1 dependientes del complejo Bul2/Rsp5. Se demostró también que la delección de *UBP2* suprimía la sensibilidad de mutantes de cohesina (*smc3-42*) a altas concentraciones de HU, sugiriendo que los eventos de ubiquitinación dependientes de Bul2/Rsp5 promueven la función de cohesina en respuesta a estrés replicativo.

Los datos recogidos en este trabajo de Tesis doctoral nos permiten proponer un modelo para la función del Bul2/Rsp5 en la respuesta de *checkpoint* de replicación. Según el modelo, cuando células sufren estrés replicativo, el complejo Bul2/Rsp5 es reclutado a las horquillas de replicación paradas dónde promueve la ubiquitinación del complejo cohesina. Tal ubiquitinación activaría el remodelamiento de la misma cohesina para favorecer el reinicio de la replicación.

## 1. ANTECEDENTES

Las células eucariotas deben preservar la integridad de sus genomas. Condiciones en las que se verifica una elevada inestabilidad genómica, caracterizada por la aparición y amplificación de mutaciones y aberraciones de cromosomas, se asocian con una elevada predisposición al desarrollo de cáncer y patologías humanas. En respuesta a estrés replicativo las células eucariotas han evolucionado un mecanismo de vigilancia,

llamado “*DNA replication checkpoint*”, que detecta la detención de las horquillas de replicación y activa una respuesta finalizada a detener la progresión del ciclo celular, estabilizar frágiles intermedios de replicación y promover la reparación de daños al ADN. Un escrutinio genético de genoma completo de la levadura *Saccharomyces cerevisiae* realizado por el equipo de investigación ha permitido identificar nuevos factores interrelacionados con la respuesta de *checkpoint* de replicación de ADN. Entre estos factores se identificó el gen *BUL2*, que codifica por el adaptador del complejo ubiquitín ligasa Bul2/Rsp5, previamente implicado en la desactivación de proteínas mediante proteólisis o relocalización subcelular y cuyos homólogos humanos, que pertenecen a la familia NEDD4, participan en procesos de transformación maligna y desarrollo del cáncer.

## 2. HIPÓTHESIS DE TRABAJO

El complejo Bul2/Rsp5 media la poli-ubiquitinación de factores específicos con la consecuente degradación o relocalización de los mismos. Datos del equipo de investigación demuestran que la eliminación de Bul2 conlleva una hipersensibilidad al tratamiento con agentes genotóxicos, por tanto, la hipótesis de este proyecto sostiene que Bul2/Rsp5 juegan un papel importante en la respuesta a estrés replicativo.

## 3. OBJETIVOS GENERALES

El objetivo principal de este proyecto de Tesis doctoral es definir el papel de Bul2/Rsp5 en la respuesta celular a estrés replicativo: i) caracterizar los mecanismos moleculares que definen la función de Bul2 en células expuestas a estrés replicativo; ii) identificar las dianas celulares de la ubiquitinación mediada por Bul2 relevantes para la respuesta a estrés replicativo; iii) caracterizar la función de las dianas de Bul2 en respuesta a la parada de horquillas de replicación.

## 4. CONCLUSIONES GENERALES

Los datos presentados en este proyecto de Tesis doctoral nos permiten presentar las siguientes conclusiones: i) eventos de ubiquitinación dependientes del complejo Bul2/Rsp5 son esenciales para reiniciar horquillas de replicación y así sobrevivir a

estrés replicativo; ii) la interacción con el complejo Mec1/Ddc2 dirige la actividad de Bul2/Rsp5 a las horquillas de replicación paradas; iii) Bul2/Rsp5 promueve el papel de cohesina en la estabilización y reinicio de horquillas de replicación paradas.

# 1. Introduction

In my thesis work I used *Saccharomyces cerevisiae* budding yeast to characterise novel factors implied in the DNA replication checkpoint response, a highly controlled process that cell activate in a specific phase of the cell cycle. *S. cerevisiae* is a globular shaped yeast belonging to the Fungi kingdom broadly used in research as model organism for genetic and citological studies. This unicellular eukaryote has a compact genome that was entirely sequenced in 1996 (12,068 kilobases contained in 16 chromosomes), thus making very easy the construction of mutants.

## 1.1 General aspects of *S.cerevisiae* cell cycle checkpoints.

The cell cycle favours the correct proliferation of a cell. It includes many genetically regulated events aimed to duplicate all cell componets. In eukaryotic cells, the entire genetic material is accuratly duplicated during S-phase: the DNA double helix unwinds and each filament is used as template to synthesise the complementary sequence. During M-phase, at the end of the cell cycle, the cell is able to segregate the genetic material and physically slpit into two complete daughter cells (cytokinesis). S and M phases are anticipated by two interphases called “gap” phases, G1 and G2 respectively, during which cells handle their normal metabolic reactions and synthesise proteins necessary for the next cell cycle phases (Fig 1.1).

In order to move from one phase to the next, a eukaryotic cell must pass through numerous checkpoints. At each checkpoint, specialized proteins determine whether the necessary conditions exist. If not, progression through the cell cycle is

halted. Errors in these checkpoints can have catastrophic consequences, including cell death or the uncontrolled growth in higher eukaryotes such as in cancer (Zeman & Cimprich, 2014). Factors involved in checkpoint pathways are highly conserved in all eukaryotes, underlining the importance of such cell cycle regulatory mechanisms.

Most of the knowledge about checkpoint pathways comes from studies in yeast cells thanks to their relatively short cell cycle. The identification and characterisation of cell cycle checkpoints has to be linked to a screening for  $\gamma$ -radiation sensitive (*RAD*) mutants performed in 1988 by Weinert and Hartwell (Weinert & Hartwell, 1988). An equivalent contribution was made in 2002 by Nyberg, who identified budding yeast genes that are not cell cycle regulators but cause cell cycle arrest after UV treatment (Nyberg et al., 2002). This led to the definition of checkpoints as mechanisms specifically involved in monitoring DNA integrity along the cell cycle. These checkpoints not only temporarily block the cell cycle, but they are also responsible for the repair of the DNA damage. They can act in three critical moments of the cell cycle: at the G1-S phase transition, during S-phase and between G2-M phases.

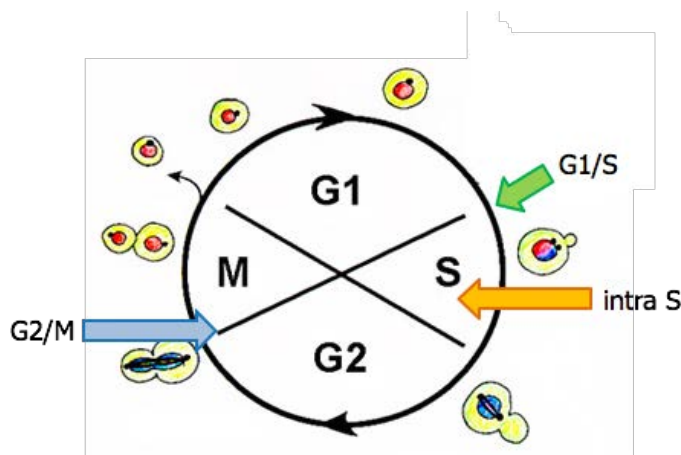

**Figure 1.1. DNA damage checkpoints.** Schematic representation of *S. cerevisiae* checkpoints activated by a DNA damage along the cell cycle: green represents the checkpoint between G1 and S phases, orange indicates the intra S-phase checkpoint and blue the G2-M checkpoint.

(Adapted from <http://utoronto.ca/andrewslab/overview.html>).

Two distinct pathways had been identified during S-phase, both aimed at preserving genome integrity: the DNA-damage and the DNA-replication checkpoints (Fig 1.1).

## **1.2 DNA replication and the DNA replication checkpoint.**

Maintaining genome integrity is crucial for all organisms. During proliferation, cells have to precisely duplicate their genetic information and accurately distribute it to daughter cells. Chromosomal DNA replication takes place in S-phase while its segregation during mitosis. Mutations in regulators of DNA replication, transcription and repair, chromosome segregation, cell cycle checkpoints and many other chromatin-related processes are responsible for genome instability (Aguilera & Gómez-González, 2008).

The DNA is a double-stranded helix and each strand of the original DNA molecule serves as a template for the synthesis of a new complementary strand. This process is referred to semi-conservative replication and “one-half” of the duplicated chromosome is defined as sister chromatid. DNA replication leads to the formation of two daughter DNA molecules each one composed of a parental and a newly synthesized strand. Concomitantly with chromosomal replication, chromatin-associated cohesin proteins physically bind together sisters chromatids in a process called sister chromatid cohesion (Wang & Christman, 2001). This step is essential for chromosome alignment in metaphase and their faithful segregation.

### **DNA replication.**

DNA replication begins at specific segments in the genome called replication origins (ORI). The specific structure of replication origins varies somewhat from species to species, but all share common characteristics such as high AT content (Yakovchuk et al., 2006). In eukaryotes, *S. cerevisiae* is the model organism where those chromosomal sequences were first identified as regions able to support the replication of mini-chromosomes and plasmids, giving rise to the name of

Autonomously Replicating Sequences (ARS) (Stinchcomb et al., 1980). Each ARS consists of a conserved 100-200 base pair sequence that serves as site for the Origin Recognition Complex (ORC), a multiprotein assembly functioning as initiator of replication.

DNA replication originates at different individual replication origins that form bidirectional replication forks. Before S-phase, each origin is licensed by combination of replication-iniation proteins (pre-replication complex) to prepare chromatin for replication. Once origins fire and DNA replication commences, cells need to balance accuracy, speed and the consumption and distribution of relevant resources, such as nucleotides and replication factors. To this end, eukaryotic cells fire replication origins in a regulated fashion, dividing them into early-replicating and late-replicating origins (Raghuraman et al., 2001). Interestingly, most licensed origins do not fire at all in an unperturbed S-phase. The “once per cell cycle” rule is enforced by global regulation of the licensing of replication origins during M and G1 phases of the cell cycle (Blow & Dutta, 2009; DePamphilis et al., 2006; Nasheuer et al., 2002).

The eukaryotic initiator ORC comprises six proteins (Orc1-6) that transiently associate with a seventh factor known as Cdc6 (Diffley & Cocker, 1992). These factors together identify and mark chromosomal origins and promote the loading of the replicative helicase onto DNA (Maiorano et al., 2000; Nishitani et al., 2000). The replicative helicase comprises an assembly of six distinct but evolutionary related minichromosome maintenance (MCM) subunits termed Mcm2-7 and it is required for DNA unwinding. The loading of Mcm2-7 onto DNA, an event that marks the licensing of replication origins (Blow, 1993), is accomplished by the joint action of ORC and Cdc6 together with a third initiator factor called Cdt1. These factors form a distinct initiation intermediate complex known as the pre-replicative complex (pre-RC) (Diffley et al., 1994; Donovan et al., 1997). Although Mcm2-7 serves as the primary motor for DNA unwinding during replication, it lacks robust activity until two additional factors, Cdc45 and the heterotetrameric

GIN5 complex, associate with the helicase (Ilves et al., 2010; Kamada, 2012), thus forming the pre-initiation complex (pre-IC).

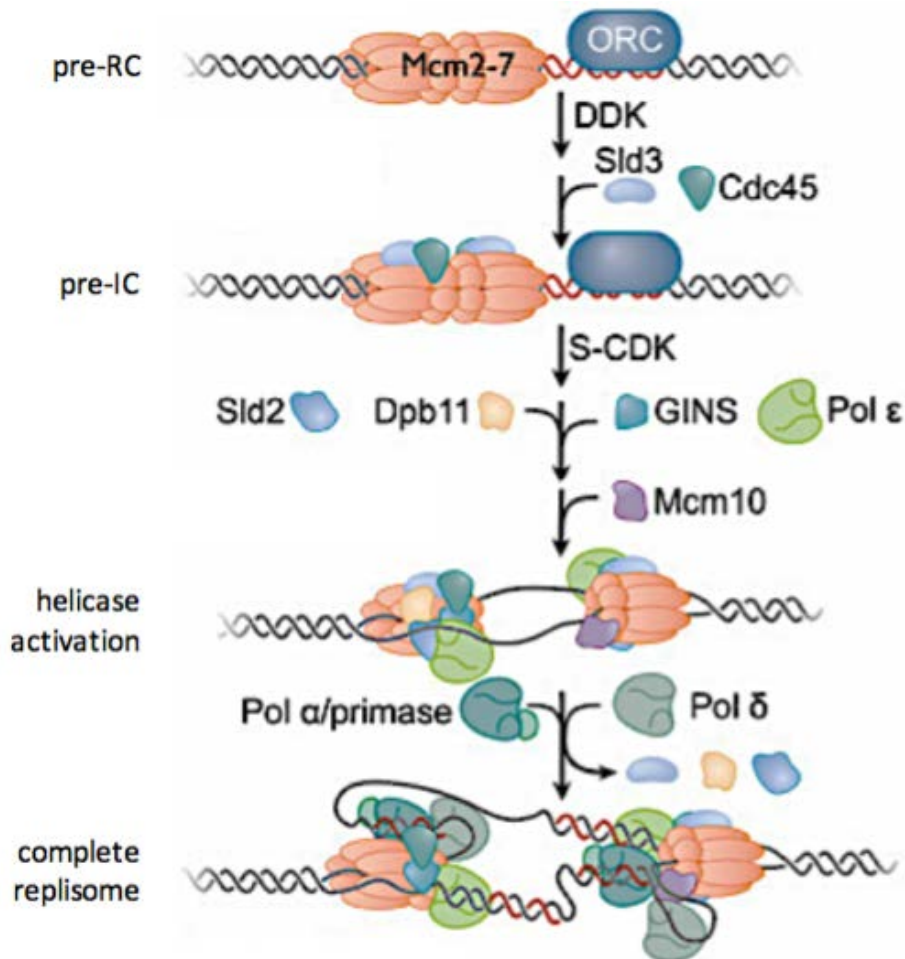
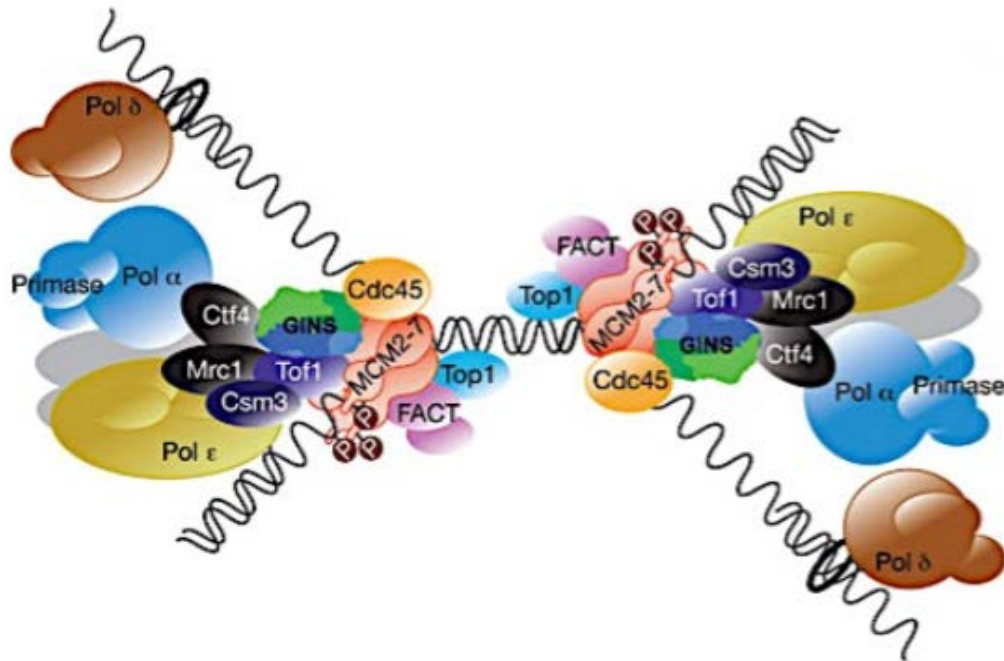

**Figure 1.2. Model for eukaryotic helicase activation and replisome assembly.** Replicative helicases are recruited to replication origins marked by the presence of the ORC complex. The initial event in helicase activation is the phosphorylation of loaded Mcm2-7 complexes by DDK. This modification leads to the recruitment of two proteins: Sld3 and the helicase activating protein Cdc45. Subsequent activation of CDK leads to the recruitment of a number of additional replication factors, including the GINS complex and the leading strand polymerase Polε. GINS is the second factor necessary for helicase activation. Recruitment of the lagging strand polymerase Polδ requires DNA unwinding and the function of the Mcm10 replication factor. (Adapted from Heller et al., 2011).

Origin firing *per se* depends on a set of cyclin-dependent kinases (CDKs) whose activity fluctuates in accordance to the phase of the cell cycle. Upon entry into S-phase, CDK and a CDK variant termed the Dbf4-dependent kinase (DDK) are activated allowing the unwinding of the DNA by Mcm2-7 and the recruitment of replication fork factors, such as DNA polymerases. CDKs modulate Mcm2-7 function by controlling the recruitment of Cdc45 and GINS through phosphorylation of specific origin activator factors (Sld2, Sld3, Dpb11 and Mcm10). Following entry into S-phase and the initiation of DNA replication, GINS and Cdc45 continue to travel with Mcm2-7 as part of the CMG complex, whereas Sld2, Sld3 and Dpb11 are lost from the DNA (Gambus et al., 2006). The entire process is schematically represented in Fig 1.2.

Genome duplication is mediated by a dynamic protein complex, known as replisome. As previously mentioned, the consequence of the firing of an origin is the formation of a replication bubble and the establishment of two replication forks. Replicative helicases assemble at the forks together with DNA polymerases and additional factors required for DNA synthesis. Helicases unwind the DNA double helix thus providing the template for replication. The resulting single-stranded DNA (ss-DNA) is stabilized by recruitment of multiple copies of the ssDNA-binding RPA complex. The established bidirectional replication bubble progresses through DNA until forks converge with others emanated from distal replication origins, thus making replication terminate. Synthesis of new DNA strands depend on specific enzymes called DNA polymerases. These enzymes act adding deoxyribonucleotides (dATP, dTTP, dCTP, dGTP) only to the free 3' end of the newly forming strand. This results in elongation of the newly DNA strand in a 5'-to-3' direction. This polarity implies that the two strands are synthesized through different mechanisms. The leading strand is replicated continuously because of the 5'-to-3' polarity of DNA polymerases. The lagging strand is replicated in a discontinuous manner by formation of small fragments of 1 to 3 Kb size, known as Okazaki fragments. DNA polymerases cannot start DNA synthesis *ex novo*, but they require an initial RNA primer that is generated by the primase

enzyme. The RNA primer is then followed by a short stretch of DNA synthesized by polymerase  $\alpha$  (Pol  $\alpha$ ).



**Figure 1.3. Schematic representation of the replisome at replication forks.** The replisome is formed by different proteins that assemble onto DNA around a replication origin. The replisome is the element required for the synthesis of new DNA strands during replication. Among the components forming the replisome we can identify the helicase complex Mcm2-7 with the function of unwinding the DNA helix. This step allows the access of the primase Pol $\alpha$ , PCNA, the RFC complex and the two polymerases Pol $\epsilon$  and Pol $\delta$ . (Adapted from Labib, 2010).

Both primase and Pol $\alpha$  reside within a single enzymatic complex. Replication factor C (RFC) complex, also known as clamp loader, binds to the primer template junction and catalyses the loading of the ring-shaped factor PCNA (Pol30 in *S. cerevisiae*) that encircles DNA. This step contributes to the association of the replicative polymerases Pol $\epsilon$  and Pol $\delta$ , which take over the synthesis from Pol $\alpha$  on leading and lagging strand respectively (Johansson et al., 2004; Yu et al., 2014) PCNA enhances the processivity of the polymerases. In the lagging strand

synthesis, when the replicative polymerase reaches the end of a previous Okazaki fragment, this is partially replaced by the proceeding DNA synthesis. At this step a flap structure is generated. Thanks to the activity of the specific flap-nuclease Rad27, the flap is cut out and the resulting nicked fragment is sealed by the DNA ligase enzyme Cdc9. The DNA ligase is also involved at the end of Okazaki fragment replication by covalently linking DNA segments synthesized to replace the RNA primers, once removed by RNase H enzymes (Fig 1.3).

As previously mentioned, PCNA is an essential cofactor for DNA synthesis as it mediates the interaction of the replication apparatus with a variety of factors involved in other cellular process such as DNA damage checkpoints, DNA repair or sister chromatid cohesion. In addition to the basic function of loader of RFC complex onto DNA, there are many other factors that physically interact with PCNA, reflecting the high level of regulation of DNA replication. Among these replication regulators there are protein kinases and phosphatases, ubiquitylating and deubiqitylating enzymes, SUMO-conjugating and deconjugating enzymes and CDK inhibitors. Therefore, replisomes are not only constituted of a DNA polymerase sliding over DNA in order to duplicate the parental strands, but represent molecular complexes of highly specialized proteins working to coordinate DNA duplication with other cellular processes. In particular, several checkpoint factors are constitutive fork components and participate both signalling problems encountered by replication forks and protecting their integrity upon genotoxic stresses.

DNA damage arising during S-phase is particularly dangerous for genome integrity. Duplication of a damaged DNA template can result in the fixation of mutations in the progeny. Moreover, unrepaired primary damage can undergo structural transformations upon passage of the replication machinery thus generating secondary lesions, such as DNA double strand breaks (DSBs) that can result in gross chromosomal rearrangements. DNA lesions arising during S-phase trigger a branch of the DNA damage checkpoint. Moreover, replication stress, such as polymerases

inhibition, deoxyribonucleotides (dNTPs) pool depletion or aberrant DNA intermediates that impede fork progression, activate a dedicated branch of the intra S-phase checkpoint which is termed as DNA replication checkpoint.

### **The DNA replication checkpoint.**

Replication stress is a complex phenomenon that has serious implications for genome stability, cell survival and human disease. DNA replication stress can arise from exogenous or endogenous factors. We can experimentally induce replication stress by treating cells with hydroxyurea (HU) (Branzei & Foiani, 2009) (Zegerman & Diffley, 2009). HU causes a reduction of the dNTP pool by inhibiting the ribonucleotide reductase (RNR), the enzyme required for dNTP synthesis (Zhao et al., 1998). Replication stress usually causes the accumulation of long stretches of ssDNA for around 300-400 nt ( dice che in wt untreated sono 220 nt while in HU treated there are additional 200 nt) due to the uncoupling of the replicative helicases that continue unwind the parental DNA and the the polymerases that have stalled (Byun et al., 2005; Nedelcheva et al., 2005; Sogo et al., 2002). The DNA replication checkpoint is an evolutionary conserved signal transduction pathway (Paulovich & Hartwell, 1995; Zhou & Elledge, 2000), which in budding yeast mainly involves Mec1 (human ATR) and Rad53 (human Chk2) kinases. This checkpoint prevents the onset of mitosis until DNA replication is completed and it is activated in response to replication stalling, treatment with genotoxic agents, abnormal DNA structures formation or replication of a damaged template (Liberi et al., 2005).

When DNA replication is blocked and cells suffer the uncoupling of DNA synthesis and unwinding, RPA (Replication Protein A) proteins bind the ssDNA stretches and this triggers the activation of the checkpoint response (You et al., 2002; Zou & Elledge, 2003). The checkpoint apical kinase Mec1/ATR is recruited by its regulatory subunit Ddc2/ATRIP to RPA-coated ssDNA at stalled forks (Zou & Elledge, 2003). Upon recruitment to DNA replication fork, Mec1 phosphorylates several factors including the mediator Mrc1/Claspin. Mrc1 is a structural

component of the replication fork required for both DNA replication and checkpoint signalling (Osborn & Elledge, 2003; Szyjka et al., 2005; Tourrière et al., 2005). In response to replication stress Mrc1 acts as a signal transducer mediating Rad53/CHK2 activation (Alcasabas et al., 2001). Mec1 phosphorylates Rad53 in an Mrc1-dependent manner, and full kinase activity of the effector kinase is achieved by subsequent events of trans hyper-autophosphorylation (Pelliccioli & Foiani, 2005). There are evidences showing that Mec1 and Rad53 are involved in replisome stabilisation in response to replicative stress, preventing forks collapse (Lopes et al., 2001; Lucca et al., 2004; Sogo et al., 2002) and this event seems to be a key step for the recovery of cells after drug removal (Tercero et al., 2003). In fact, the loss of DNA polymerases, replication protein A and the putative helicase, likely leads to replication fork collapse and chromosomal breakage (Cobb et al., 2005; Lucca et al., 2004). Moreover Mrc1 prevents extensive uncoupling between helicases unwinding and DNA synthesis at stalled forks by somehow tethering DNA helicases to DNA polymerases (Katou et al., 2003; Nedelcheva-Velleva et al., 2006). In fact, Mrc1 interacts with polymerase  $\epsilon$  catalytic subunit Pol2 in a checkpoint-dependent manner (Lou et al., 2008), thus suggesting a role of Mrc1 as sensor of the physical connection between helicases and polymerases.

Modulation of cellular physiology in response to replication stress is ultimately achieved through the regulation of different downstream effectors. Mec1 is thought to act locally by phosphorylating replication fork-associated (Randell et al., 2010; Smolka et al., 2007) and chromatin factors (Randell et al., 2010; Rodriguez & Tsukiyama, 2013). By contrast several Rad53 targets are not always localized at the fork (Chen et al., 2010; Smolka et al., 2007) consistent with the notion that Rad53 may diffuse and propagate checkpoint signal to distant effectors throughout the nucleus (Jossen & Bermejo, 2013). The checkpoint response leads to upregulation of dNTP pools through Dun1 kinase activation, inhibition of origin firing (J. a Tercero & Diffley, 2001), stabilisation of replisomes around stalled forks, transcriptional induction of damage inducible genes and modulation of DNA repair (Fig 1.4).

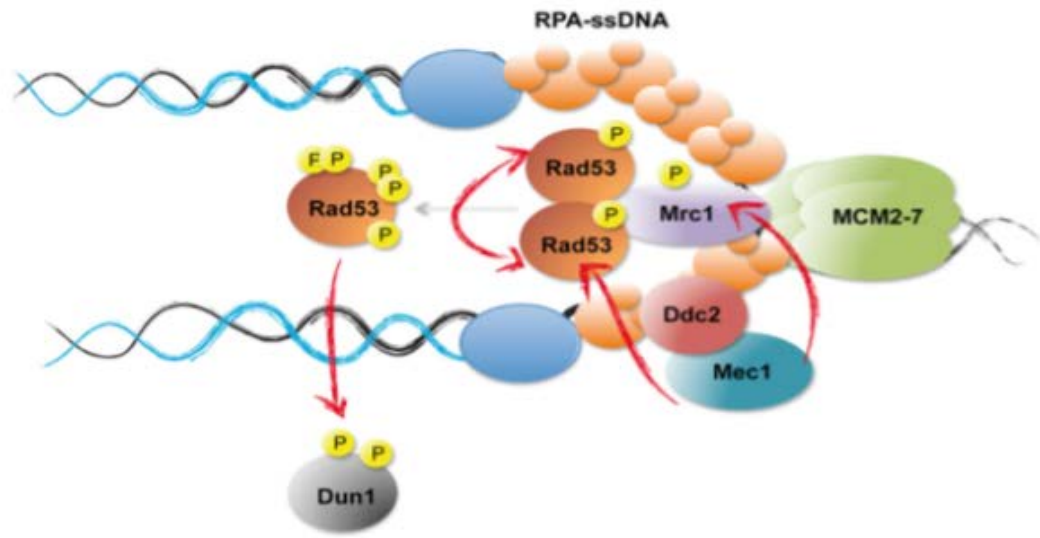

**Figure 1.4. Checkpoint activation in response to replication stress.** Upon replication fork stalling, ssDNA is generated by uncoupling of replicative helicases and DNA polymerases. Long stretches of ssDNA coated by RPA mediate the recruitment of the apical checkpoint kinase Mec1 to replication forks through its associated factor Ddc2. Mec1 phosphorylates fork components, including Mrc1 and the Rad53 effector kinase. Mrc1 serves as a scaffold promoting Rad53 trans-autophosphorylation events necessary for full activation of the effector kinase. Rad53 phosphorylates and activates the effector kinase Dun1 and propagates checkpoint signal to distant effectors. (Adapted from Jossen & Bermejo, 2013).

### 1.3 DNA replication and cohesin.

Physical pairing between sister-chromatids plays a vital role in the faithful transmission of genetic information during cell division. In eukaryotes, this pairing is mediated primarily by cohesin, a ring-shaped multiprotein complex that appears to catenate DNA molecules by topological means (Nasmyth & Haering, 2009). An important feature of cohesin is that its ability to form such linkages is tightly regulated and, under normal conditions, occurs only during S-phase, when new sister DNAs are synthesized. Cohesin is involved in many DNA-related processes such as proper chromosome segregation, replication, transcription and repair.

Mutations in genes involved in cohesin function are responsible for human diseases, collectively referred to as “cohesinopathies” (Deardorff et al., 2007; Liu & Krantz, 2008; Press, 2013). In addition both cohesin gene expression dysregulation and mutations have been identified in cancer cells.

Cohesin is a member of a large family of DNA-associated complexes based on highly conserved SMC (Structural Maintenance of Chromosome) proteins. All SMC proteins use intramolecular coiled-coil interactions to fold themselves, producing rod-shaped molecules with an ATPase head domain and dimerizing hinge at either ends (Hirano & Hirano, 2006). In the case of budding yeast, the core cohesion complex is composed of four subunits: two elongated proteins, called Smc1 and Smc3, and two non-SMC subunits, called Scc1 or Mcd1 and Scc3. The Smc1 and Smc3 head groups interact to form a pair of intra-molecular ATPase, and the hinge domains at the other extremity interact with Scc1, thus forming a closed ring of 45 nm (Arumugam et al., 2006; Gruber, Haering & Nasmyth, 2003; Haering et al., 2002). Scc1 also interacts with the non-SMC subunit Scc3. The Scc3 subunit binds to the central domain of Scc1 and completes the cohesin ring (Haering et al., 2002). Similarly, Pds5 protein is also associated with cohesin and important for cohesion establishment (Kulemzina et al., 2012; Panizza et al., 2000) (Fig 1.5).

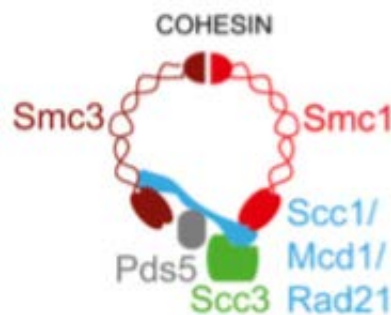

**Figure 1.5. Cohesin structure.** A model for the arrangement of cohesin subunits. The structure is a tripartite ring made up of two SMC proteins (Smc1 and Smc3) and a kleisin subunit (Scc1), which is thought to make asymmetric contacts with the SMC proteins. Additional non-SMC subunits, Scc3 and Pds5, form part of the complex, interacting with Scc1 (Adapted from Marston, 2014).

Considerable evidence supports the notion that cohesin ring topologically entrap sister DNAs together (Haering et al., 2002; Nasmyth & Haering, 2009), with DNA entering the ring via ATP-dependent opening of the Smc1-Smc3 hinge interface (Arumugam et al., 2003; Gruber et al., 2006; Weitzer et al., 2003). The interaction of cohesin with chromosomes is regulated by a number of proteins, which collectively ensure proper cohesin dynamics in response to cell cycle progression. This cohesin cycle is referred to the binding of cohesin to chromatin, the tethering of sister chromatids and finally release of chromatids at cell division (Fig 1.6).

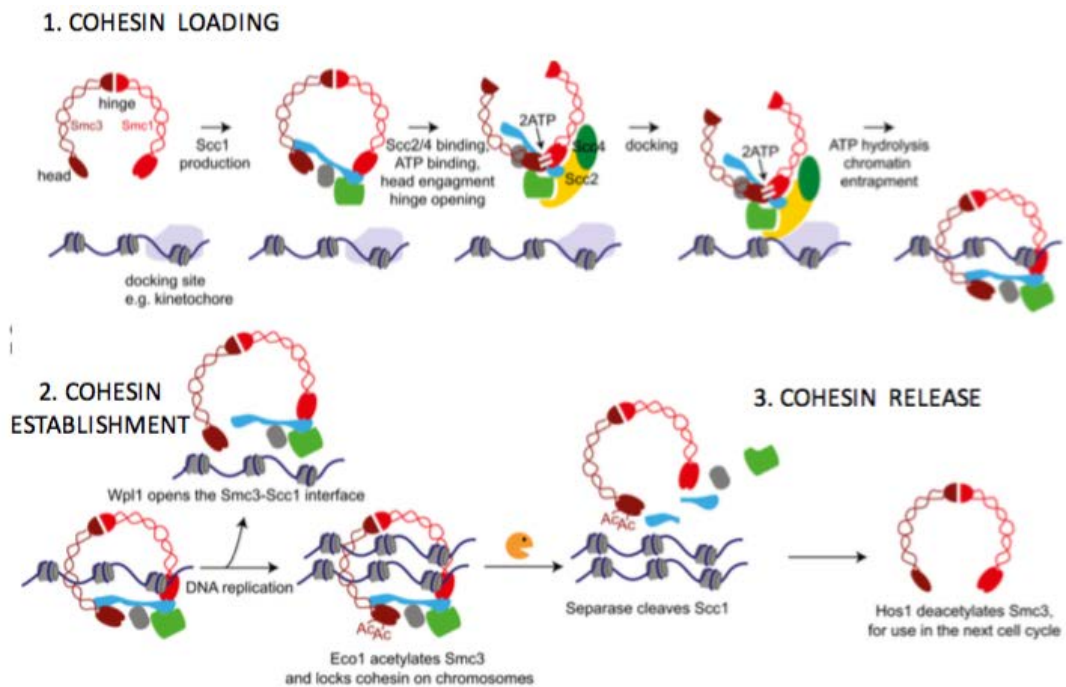

**Figure 1.6. The chromosome cohesin cycle.** A current model for cohesin loading, establishment and release. Cohesin loading involves opening of the Smc1 and Smc3 hinge and requires the Scc2/Scc4 protein and ATP binding to the SMC heads. Cohesin is unstable on chromosomes due to the activity of Wpl1, which opens the Smc1-Smc3 interface. Eco1 acetylation makes cohesin refractory to Wpl1, effectively locking the ring. Cohesin is released following the opening of the ring at anaphase onset. This process depends on Scc1 cleavage by separase. Hos1 deacetylase recycles Smc1 and Smc3 for use in the next cell cycle by removing the acetyl mark on Smc3 (Adapted from Marston, 2014).

### **Cohesin loading.**

In yeast, cohesin associates with chromatin during late G1-phase in a process requiring a heterodimeric complex composed of Scc2 and Scc4 proteins (Ciosk et al., 2000; Tomonaga et al., 2000; Bernard et al., 2006). Timed temperature shift experiments in *S. cerevisiae* suggest that the Scc2-Scc4 complex, also known as SMC loader, becomes dispensable for cohesion as cells enter S-phase (Lengronne et al., 2004a) suggesting that cohesin must be loaded onto chromosomes before S-phase onset. Once cohesin is loaded onto chromatin, the cohesin-interaction proteins Pds5 and Wapl associate to the complex (Kueng et al., 2006).

### **Cohesin establishment.**

The pre-replicative loading of cohesin is necessary but not sufficient to ensure that sister chromatids are ultimately linked to one another. More crucial for cohesin establishment is the Eco1 factor (Skibbens, 2009), an acetyltransferase conserved throughout the eukaryotic kingdom (Williams et al., 2003). The essential function of Eco1 is to acetylate a pair of adjacent lysine residues (K112 and K113) of Smc3 (Rowland et al., 2009; Unal et al., 2008; Zhang et al., 2008). Acetylation of Smc3 by Eco1 occurs during S-phase, is maintained throughout G2 and M phases and only removed by the deacetylase Hos1 (Beckouët et al., 2010) upon cleavage of Scc1 by separase at anaphase onset. Early studies in budding and fission yeast demonstrated that Eco1 executes its cohesion-promoting role during S-phase, but is not required for cohesin loading in G1-phase or maintenance of cohesion in G2 and M phase (Skibbens, 2009), thus distinguishing it from both the Scc2-Scc4 complex and cohesion itself. Smc3 acetylation peaks in S-phase and defends cohesin against an “anti-establishment” activity associated with Pds5 and Wapl (Sutani et al., 2009; Tanaka et al., 2001) Sister chromatid cohesion requires the identification and pairing of two identical copies of each chromosome or homologs (Gligoris et al., 2014.). A natural context for these transactions exists at the replication fork, which provides a temporary bridge between sister DNAs. Indeed, considerable physical and functional evidence links both Eco1-dependent

acetyltransferase and other cohesion establishment factors to replication forks (Ryu et al., 2006): Eco1 itself contains a conserved PCNA-binding motif that is essential for its cohesive activity (Lengronne et al., 2004). Finally, multiple components of the replisome progression complex (RPC), which couple the activated form of the Mcm2-7 helicase to the leading and lagging strand machinery, are also important for cohesion establishment, like Mrc1, Tof1 and Csm3 proteins (Fenius & Marston, 2009; Hanna et al., 2001; Mayer et al., 2004) which stabilize stalled replication forks and transduce checkpoint signals in concert with DNA polymerase  $\epsilon$  on the leading strand (Leman et al., 2010).

### **Cohesin release.**

Following cohesin loading and DNA replication-dependent cohesion establishment, sister chromatids remain tethered together by cohesin until anaphase onset. At this step the cohesin ring is opened triggering sister chromatid disjunction (Uhlmann et al., 1999). Two mechanisms account for cohesin's release from chromosomes. Best understood is cleavage of Scc1 subunit by separase (Kogut et al., 2009; Uhlmann et al., 2000). The N- and C-terminal Scc1 fragments associated with Smc3 and Smc1 ATPase heads, respectively, are degraded by the APC/C<sup>Cdc20</sup> E3 ubiquitin ligase as daughter cells enter a new cell cycle (Gruber et al., 2003). The critical substrate of the APC/C at anaphase is not cohesin itself, but the anaphase inhibitor Pds1 or securin (Ciosk et al., 1998). Securin binds to and inhibits the separase Esp1, a cysteine protease responsible for the cleavage of the Scc1 subunit.

The second mechanism is independent of separase but requires a regulatory subunit associated with cohesin called Wapl (Gandhi et al., 2006; Kueng et al., 2006). In addition to Wapl, releasing activity depends on K112 and K113 residues within Smc3 in their unmodified state and on Pds5 and Scc3 proteins (Chan et al., 2013; Hara et al., 2014; Roig et al., 2014; Rowland et al., 2009). This releasing mechanism is responsible for the dissociation of Scc1's N-terminal and Smc3's coiled-coil domain. It operates throughout the cell cycle and is responsible for

choesin's turnover on interphase chromatin (Chan et al., 2012). Because it has the potential to destroy sister chromatid cohesion, this releasing activity must be neutralized after replication, at least for the chromosomal cohesin pool destined to hold sister DNAs together during mitosis. This is the function played by Eco1-mediated acetylation of K112 and K113 on Smc3, which, at least in yeast, seems sufficient to block releasing activity (Beckouët et al., 2010; Beckouët et al., 2016).

#### 1.4 DNA replication and ubiquitination.

Ubiquitin is an abundant, highly conserved 8 kDa protein that is found in all eukaryotes. Since its initial discovery in the early 1980s, ubiquitin has been found to be involved as a regulator in many essential and important processes. At first, ubiquitin was thought simply to be a signal to trigger degradation of proteins by the 26S proteasome, a large multiprotein complex responsible for degradation of ubiquitinated substrates. However, recent studies identified ubiquitin as a crucial regulator in many non-proteolytic events. These events include pathways linked to cell cycle progression, mitosis, chromosomal segregation, signal transduction and DNA damage repair.

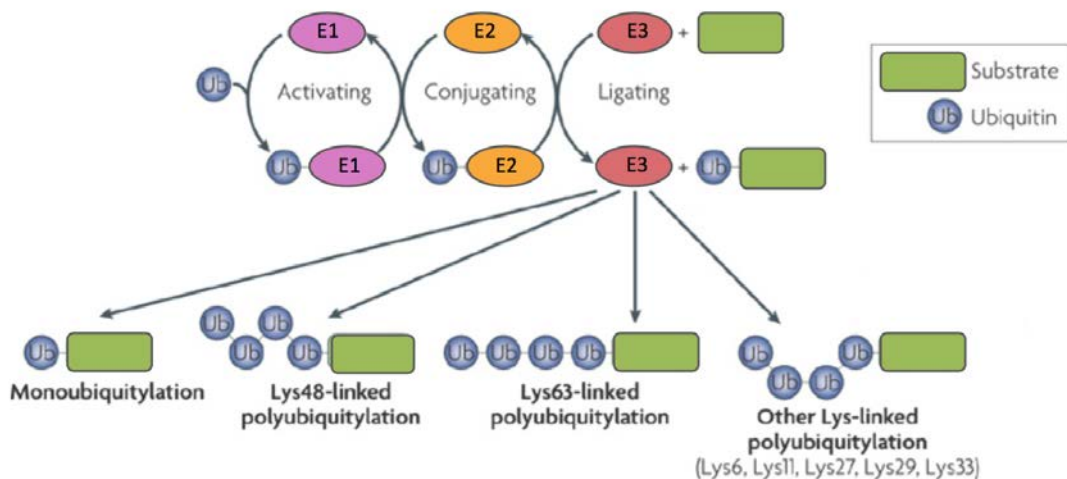

**Figure 1.7. The ubiquitylation cascade.** The activity of three enzymes is required for ubiquitylation: an ubiquitin-activating enzyme (E1), an ubiquitin-conjugating enzyme (E2)

and an ubiquitin-ligase enzyme (E3) that recognizes the substrate. The completion of one ubiquitylation cycle results in a mono-ubiquitylated substrate. However, the cycle can be repeated to form poly-ubiquitylated substrates. Additional ubiquitin molecules (Ub) can be ligated to a lysine residue (Lys6, Lys11, Lys27, Lys29, Lys33, Lys48 or Lys63) in a previously attached ubiquitin to form Lys-linked chains. (Adapted from Dikic et al., 2009)).

Ubiquitylation involves the sequential transfer of activated ubiquitin between an ubiquitin-activating enzyme (E1), an ubiquitin-conjugating enzyme (E2) and an ubiquitin-ligase (E3) that facilitates the transfer of ubiquitin (Ub) to one or more lysine (Lys) residues in the substrate (Fig 1.7). While all E2 conjugating enzymes possess a common conserved catalytic domain, a number of E2s have specificity for a single E3 (Pickart, 2001).

Proteins can be modified by a single ubiquitin (mono-ubiquitination) or a poly-ubiquitin chain. There are seven lysines among the 76 aminoacids in ubiquitin, all of which are targets for the formation of different poly-ubiquitin chains. Poly-ubiquitin chains joined at lysine positions 6, 11, 27, 29, 33, 48 and 63 (P. Xu et al., 2010). Till now the best-studied types of poly-ubiquitin chains involve K48 and K63 chains. Generally, K48 poly-ubiquitin chains target substrates to the 26S proteasome, while K63-linked chains result in various non-proteolytic fates (for a complete review see (Komander & Rape, 2012)).

Like most post-translational modifications, ubiquitylation is a dynamic and reversible process dependent on a specific class of proteases called the deubiquitylating enzymes (DUBs). The diversity of DUB families and abundance of individual members suggests a high degree of specificity both in terms of substrate and ubiquitin chain-type recognition. Important advances have been done in establishing the regulation of the DNA damage response by ubiquitylation and deubiquitylation, with many ubiquitin ligases and proteases involved in genome stability, often regulating multiple proteins in the same pathway (Nishi et al., 2014). For example, in mammals the DUB enzyme USP7 not only regulates CLASPIN (Mrc1 in *S.cerevisiae*) levels, but also directly deubiquitylates CHK1 (Vega et al., 2014) and RNF168 (Zhu et al., 2015), whereas USP28 controls the levels of

53BP1 and CHK2 (Rad53 in *S.cerevisiae*) (Zhang et al., 2006). Moreover ubiquitin ligase enzymes have an important role in recruiting key DNA repair factors into nuclei foci to DSB sites. In mammals this recruitment relies on K63-linked ubiquitylation of histones and other chromatin-associated proteins by the E3 ligases RNF8 and RNF168, generating binding sites for DNA repair factors at chromatin flanking DSBs (Doil et al., 2009; Kolas et al., 2007; Panier et al., 2012).

The best-studied process that exemplifies the role of ubiquitination and deubiquitylation in coordinating and co-regulating the complex cellular responses that maintain genome integrity is represented by post-translational modifications of the clamp loader PCNA (for a complete review (McIntyre & Woodgate, 2015; Xu et al., 2014). As previously mentioned, the presence of DNA lesions during S-phase that block the progression of replication forks is a major challenge to the cell. If not dealt with, blocked replication forks can collapse, resulting in double-stranded breaks (DSBs) that can lead to cell death or genome rearrangements. To circumvent these problems, PCNA is ubiquitylated at a conserved lysine (K164). K164 ubiquitylation can either be mono-ubiquitylated or poly-ubiquitylated. Ubiquitylation of PCNA (Pol30 in *S. cerevisiae*) is necessary to bypass DNA lesions by translesion DNA synthesis (TLS) or “error-free bypass” pathways. How cells make the decision between error-prone TLS versus the error-free bypass pathway is regulated through the ubiquitylation state of PCNA. Rad18-dependent mono-ubiquitylated PCNA serves as signal to activate TLS pathway (Bienko et al., 2005; Hoege et al., 2002). Extension of this initial ubiquitin signal by the Rad5 ligase to form a K63-linked poly-ubiquitin chain, results in a switch to a recombinant-dependent error-free DNA repair pathway (Broomfield et al., 1998; Hoege et al., 2002). This regulatory mechanism based in covalent modifications of the Lys164 of the sliding clamp PCNA is a solid established model conserved in all eukaryotes (Bergink & Jentsch, 2009; Branzei & Foiani, 2009). It is reasonable to think that as ubiquitylation of PCNA leads to the bypass of a DNA lesion, cells may need a control mechanism that deubiquitylates Ub-PCNA as soon as TLS DNA polymerases

have been able to replicate over the damage site. In humans, USP1 has been identified as the protease that deubiquitylates monoubiquitylated PCNA after UV-light induced DNA damage (Huang et al., 2006). In yeast it has been recently demonstrated that a safeguard mechanism to limit TLS DNA polymerase is played by Ubp10 in *S. cerevisiae* (Gallego-Sánchez, Andrés, Conde, San-Segundo, & Bueno, 2012) and a set of DUBs enzymes in *S. pombe*, Ubp2, Ubp15 and Ubp16 (Álvarez et al., 2016).

### 1.5 Rsp5/Bul2 ubiquitin ligase complex.

As previously mentioned, ubiquitin is covalently attached to a substrate via an energy three-step process, involving an E1, E2 and E3 enzyme. The E3 ubiquitin ligase largely determines the substrate specificity of the system.

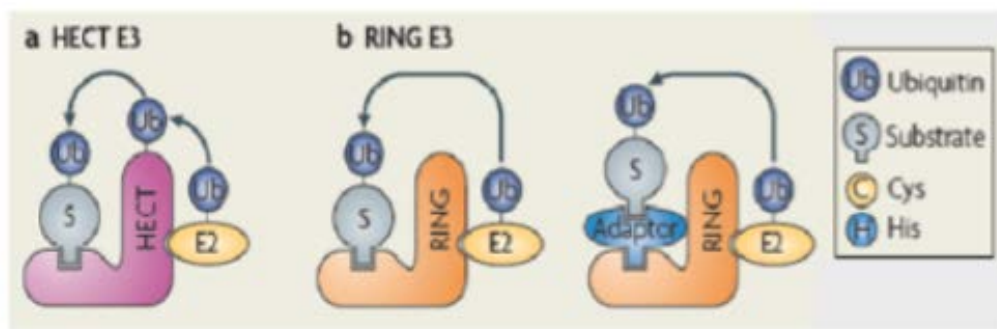
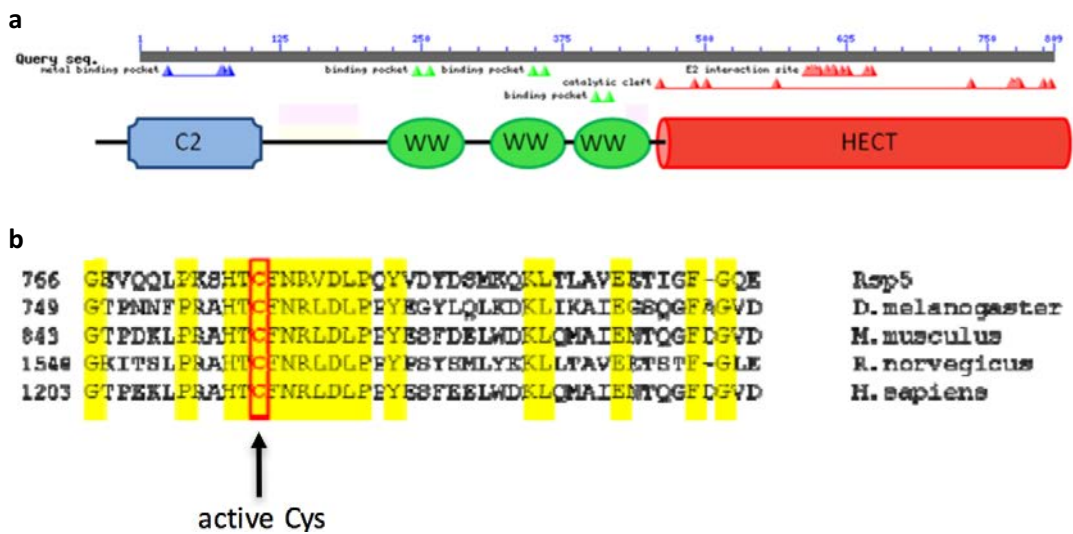

**Figure 1.8. Classes of E3 ubiquitin-ligase enzymes.** The two main classes of ubiquitin ligases are shown. a) HECT E3s work as acceptor of ubiquitin (Ub) thanks to a conserved cysteine (Cys) residue; b) RING E3s function as scaffolds for the interaction between E2 and substrate. (Adapted from Rotin & Kumar, 2009).

The ubiquitin protein ligases can be grouped into two main classes: protein complexes with a RING-finger catalytic domain (Deshaies & Joazeiro, 2009) and ligases containing a HECT domain (Rotin & Kumar, 2009). The two classes differ in the way they transfer ubiquitin to the substrate: HECT E3s are enzymes that contain a conserved catalytic Cysteine (Cys) acting as an acceptor of ubiquitin from

an E2 enzyme; conversely, RING E3s act as scaffolds by facilitating the interaction between E2 and the substrate (Fig 1.8).

One of the best-studied ubiquitin ligase in the eukaryotic system budding yeast is Rsp5, the single essential 809 aminoacid NEDD4-family member in *S. cerevisiae* (Rotin et al., 2009). Rsp5 has a typical NEDD4-family domain structure consisting of a C2 domain, three WW domains and a HECT domain (Fig 1.9a).



**Figure 1.9. *S. cerevisiae* Nedd4-like Rsp5 ubiquitin ligase.** Schematic representation of Rsp5 structure. a) Domain architecture of yeast Rsp5 adapted from NCBI database; b) Alignment of the HECT domain end sequences of yeast Rsp5, drosophila Nedd4, mouse NEDD4-1, rat NEDD4 and human Nedd4-1. Sequence identity is shown in yellow and the catalytic cysteine (Cys) is marked in red.

The C2 domain, about 130 amino acids long, is a conserved lipid- and protein-interaction module often regulated by calcium ( $\text{Ca}^{2+}$ ). It is not necessary for the essential function of Rsp5, but it is implicated in Rsp5-dependent sorting of cargo proteins (Dunn et al., 2004). The WW domains are three-stranded anti-parallel  $\beta$ -sheet forming a hydrophobic pocket (Macias et al., 1996) that mediates protein-protein interactions by recognizing PY (proline-rich) motives. The catalytic HECT domain is about 350 residues and is located at the C-terminus of Rsp5. The domain is essential for the ubiquitylation activity of the protein and contains a

highly conserved cysteine residue (Fig 1.9b): mutation of the conserved catalytic Cys results in a complete loss of function of Rsp5 (Kaliszewski & Zoładek, 2008).

Rsp5 is an essential and key regulator in the cell. Rsp5 substrates are typically modified either by addition of a single ubiquitin or K63 poly-ubiquitin chains (Wilson et al., 2013). Apart from roles in intracellular trafficking of transmembrane proteins, transporters and receptors, Rsp5 has been implicated in the regulation of various nuclear processes. For example, Rsp5 is involved in the ubiquitination and subsequent degradation of the large subunit of RNA polymerase II (Rpb1) (Huibregtse et al., 1997; Kaliszewski & Zoładek, 2008). It has been shown that in response to DNA damage Rsp5 adds a non-degradative K63-linked poly-ubiquitin chain to Rpb1, which can then be trimmed down to a mono-ubiquitin signal by the specific DUB enzyme Ubp2 (Harreman et al., 2009). Rsp5 is also involved in the ubiquitination and proteasome-dependent degradation of the transcription factors Spt23 and Mga2 (T Hoppe et al., 2000).

While Rsp5 is able to directly interact with some of its targets, in other cases substrate interaction is mediated by adaptor proteins. Two well-known Rsp5 cofactors are Bul2 and its paralog Bul1. The Rsp5-Bul1/2 complex, first identified through yeast two-hybrid screens (Yashiroda et al., 1998), has been implicated in the regulation of Rsp5-dependent ubiquitination at different steps in the vesicle trafficking cascade. For example, in response to nitrogen, the ability of Rsp5 to mono- versus poly-ubiquitinate the general aminoacid permease Gap1 is altered by the presence of its adaptors. Bul1 and Bul2 bind to Rsp5 via PY-WW-mediated interaction (Watanabe et al., 2015; Yashiroda et al., 1998). In the absence of Bul1 and Bul2, the permease is mono-ubiquitinated by Rsp5 and localises to the plasma membrane whereas, in the presence of Bul1 and Bul2, Gap1 is poly-ubiquitinated by Rsp5 and is transported to the vacuole for degradation (Helliwell et al., 2001; O'Donnell, 2012)

*BUL2* stands for Bind Ubiquitin Ligase 2 and codifies for a 105 KDa protein with an internal PY motif important for its interaction with Rsp5 (Gupta et al., 2007). Bul1 and Bul2 act as modulators of the Rsp5-mediated ubiquitination by promoting

polyubiquitin chain elongation starting from mono-ubiquitinated substrate or by ramifying short polyubiquitin chains, thus influencing protein function and localisation (Hoppe, 2005) (Fig 1.10). It has been demonstrated that the Rsp5-Bul2/Bul1 complex is involved in the activation of gene transcription mediated by HSE elements (Heat Shock Elements), suggesting a nuclear localisation of the complex with the function of poly-ubiquitinates components of the transcription machinery thus modulating gene expression. In the absence of both Bul1 and Bul2 there is not HSE-mediated gene expression (Kaida et al., 2003).

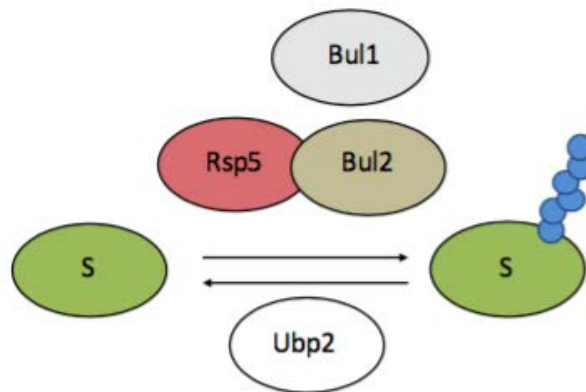

**Figure 1.10. Model of Rsp5/Bul2 mediated regulation of substrates.** The E3 ligase Rsp5 is responsible for substrate ubiquitylation. Rsp5  $\alpha$ -arrestin adaptors Bul2 and Bul1 modulate Rsp5-dependent ubiquitylation by introducing poly-ubiquitin chains from mono-ubiquitinated substrate or by ramifying short poly-ubiquitin chains.

As mentioned previously, the cleavage of ubiquitin chains from ubiquitinated proteins is performed by a group of proteases termed deubiquitinating enzymes (DUBs) (Amerik & Hochstrasser, 2004). DUBs reverse the poly-ubiquitination of substrate proteins and facilitate ubiquitin removal at the proteasome, a step necessary for the recycle of ubiquitin in the cell. It has been shown that Ubp2 is important for proper trafficking at the multivesicular body (MVB) of Rsp5 membrane protein substrates, including the uracil permease Fur4 (Lam & Emili,

2013; Lam, 2010) indicating that Ubp2 is the specific DUB responsible to reverse the K63-linked polyubiquitin chains catalyzed by Rsp5 (Kee et al., 2005) (Fig 1.10). In this thesis I will present and discuss data that reveal the importance of the Rsp5-Bul2 ubiquitin ligase complex in the process of replication fork re-start, uncovering a fascinating interplay between cohesin ubiquitilation and replication fork stability.



## 2. Objectives

The aim of this PhD thesis is to investigate the function of the Bul2 ubiquitin ligase adaptor protein in the cellular response to replication stress.

Objectives:

- 1) Characterizing the molecular mechanism underlying Bul2 function in cells experiencing replication stress.
- 2) Identifying targets of Bul2-mediated ubiquitylation relevant to replication stress response.
- 3) Characterizing the function Bul2 targets in response to replication fork stalling.



## 3. Results

### 3.1 The Bul2/Rsp5 complex is involved in the cellular response to replication stress.

#### 3.1.1 Bul2/Rsp5-mediated ubiquitylation events are required to survive replication stress.

A previous genome-wide screening carried out in *Saccharomyces cerevisiae* led to the identification of Bul2 as a novel factor interplaying with the replication checkpoint response to replication stress. Bul2 (**B**inds **U**biquitin **L**igase 2) is an adaptor component of the Rsp5 E3-ubiquitin ligase (Hoppe, 2005). By serial dilutions we showed that deletion of *BUL2* renders cells sensitive to hydroxyurea (HU) treatment (Fig 3.1a), indicating its implication in the response to replication stress induced by dNTP depletion.

Bul2 and its paralog Bul1 (Andoh et al., 2000) work as modulators of Rsp5 function by conferring substrate specificity and promoting polyubiquitin chain elongation. Since Bul1 and Bul2 exhibit high sequence identity (Yashiroda et al., 1996) and *bul* phenotypes have been reported in *bul1Δ bul2Δ* double mutants only (Andoh et al., 2000; Crespo et al., 2004; Kaida et al., 2003), it has been considered that Bul1 and Bul2 are functionally redundant (Yashiroda et al., 1998). We thus dissected the role of Bul1 and Bul2 in the response to HU-induced replication stress using serial dilutions. For this purpose, we generated *bul1Δ* single and *bul1Δ bul2Δ* double mutants. We also investigated the role of the E3 ubiquitin ligase in the replication

stress response, taking advantage of two mutant alleles of the essential gene *RSP5*. The *rsp5-1* mutation is located within the HECT ubiquitin ligase domain (L733S) and impairs enzymatic activity of the purified protein in vitro (Wang et al., 1999). The *rsp5-25* allele contains two changes in its open reading frame (ORF). The first mutation causes a tyrosine-to-ochre codon change, thus truncating the protein in a *sup4* background. The ochre mutation-dependent lethality is partially suppressed by the tyrosine-inserting tRNA suppressor, *SUP4-o*. The second mutation results in the substitution of a tryptophan residue with a leucine residue in the HECT domain. Both mutations are required in order to observe the ubiquitilation defects in *rsp5-25* (Erdeniz & Rothstein, 2000).

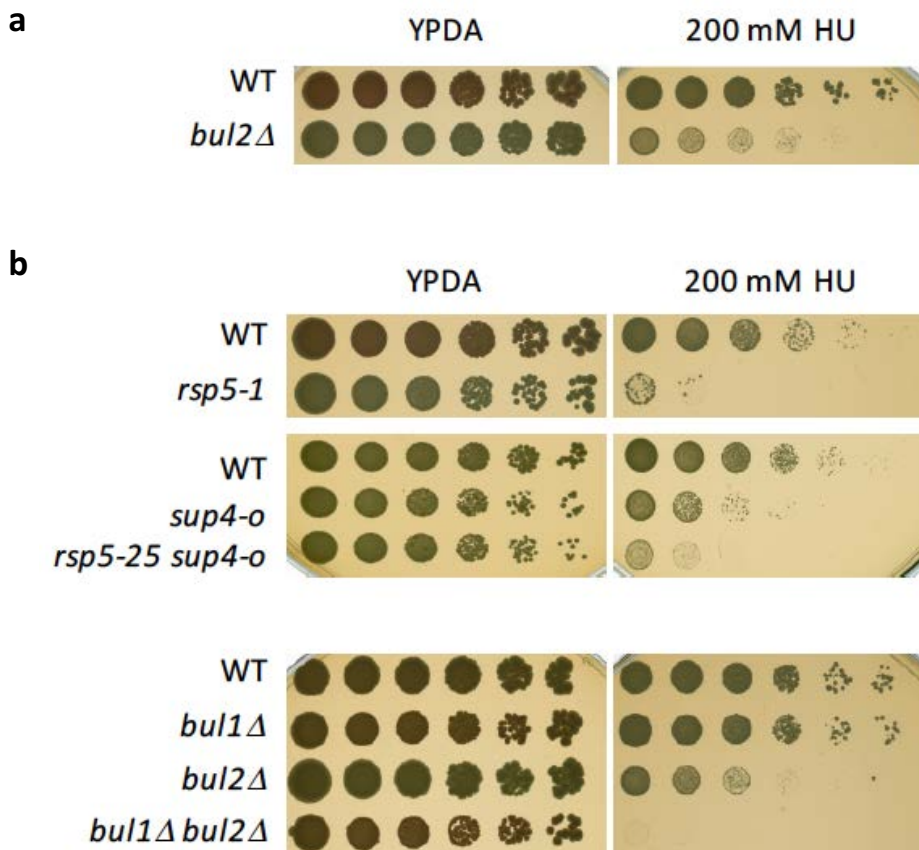

**Figure 3.1. HU sensitivity of Rsp5/Bul1-Bul2 ubiquitin ligase complex mutants.** (a-b) 10X serial dilutions of WT, *rsp5-1*, *rsp5-25 sup4-o*, *sup4-o*, *bul1Δ*, *bul2Δ* and *bul1Δ bul2Δ* mutants were plated on YPDA medium in the absence or presence of the indicated HU concentration.

We scored for the HU sensitivity of *RSP5* alleles, *BUL1*, *BUL2* and double *BUL1 BUL2* deletion mutants (Fig 3.1b). Both *rsp5-1* and *rsp5-25* mutations caused severe growth defects in the presence of HU. Deletion of *BUL1* did not render cells sensitive to HU, while *bul1Δ bul2Δ* mutants were highly HU sensitive. These results indicate that: i) Rsp5 E3 ubiquitin ligase is required to survive to HU-induced replication stress; ii) Bul2 is likely the primary adaptor for Rsp5 in the response to HU-induced replication stress; iii) in the absence of Bul2, Bul1 may inefficiently take over Bul2 function in the replication stress response.

Ubp2 is a deubiquitin enzyme (DUB) responsible to reverse the K63-linked polyubiquitin chains catalyzed by Rsp5 (Kee et al., 2005) (Fig 1.10). Data from our group demonstrated that deletion of *UBP2* suppressed the HU sensitivity of *bul2Δ* mutants but not *bul1Δ bul2Δ* (data not shown), suggesting that Rsp5/Bul2-mediated ubiquitylation levels are important for replication stress survival and that in the absence of both adaptors HU-relevant Rsp5 ubiquitylation is severely impaired. Altogether these data demonstrate that the Bul2/Rsp5 ligase plays an important role for cells to respond to replication stress.

### 3.1.2 Bul2/Rsp5 is required for efficient chromosome duplication in the presence of HU.

We compared genome bulk duplication of WT and *bul1Δ bul2Δ* cells. We used the double mutant *bul1Δ bul2Δ* to abrogate Rsp5-mediated ubiquitylation events relevant to replication stress response. Logarithmically growing cells were synchronized in G1 by  $\alpha$ -factor treatment and then released into S-phase in the presence of 200mM HU. DNA synthesis was monitored by Fluorescence-Activated Cell Sorting (FACS) (Fig 3.2a). Under these experimental conditions WT cells were able to slowly replicate DNA, while *bul1Δ bul2Δ* mutants showed DNA contents close to 1C along the time course. Bulk genome duplication defects of cells lacking

*BUL1* and *BUL2* genes can be clearly appreciated by merging of WT and *bul1Δ bul2Δ* cells FACS profiles.

In contrast, *bul1Δ bul2Δ* cells released from a G1 block into an unperturbed S-phase reached a 2C DNA content with the same kinetics of WT cells (Fig 3.2b).

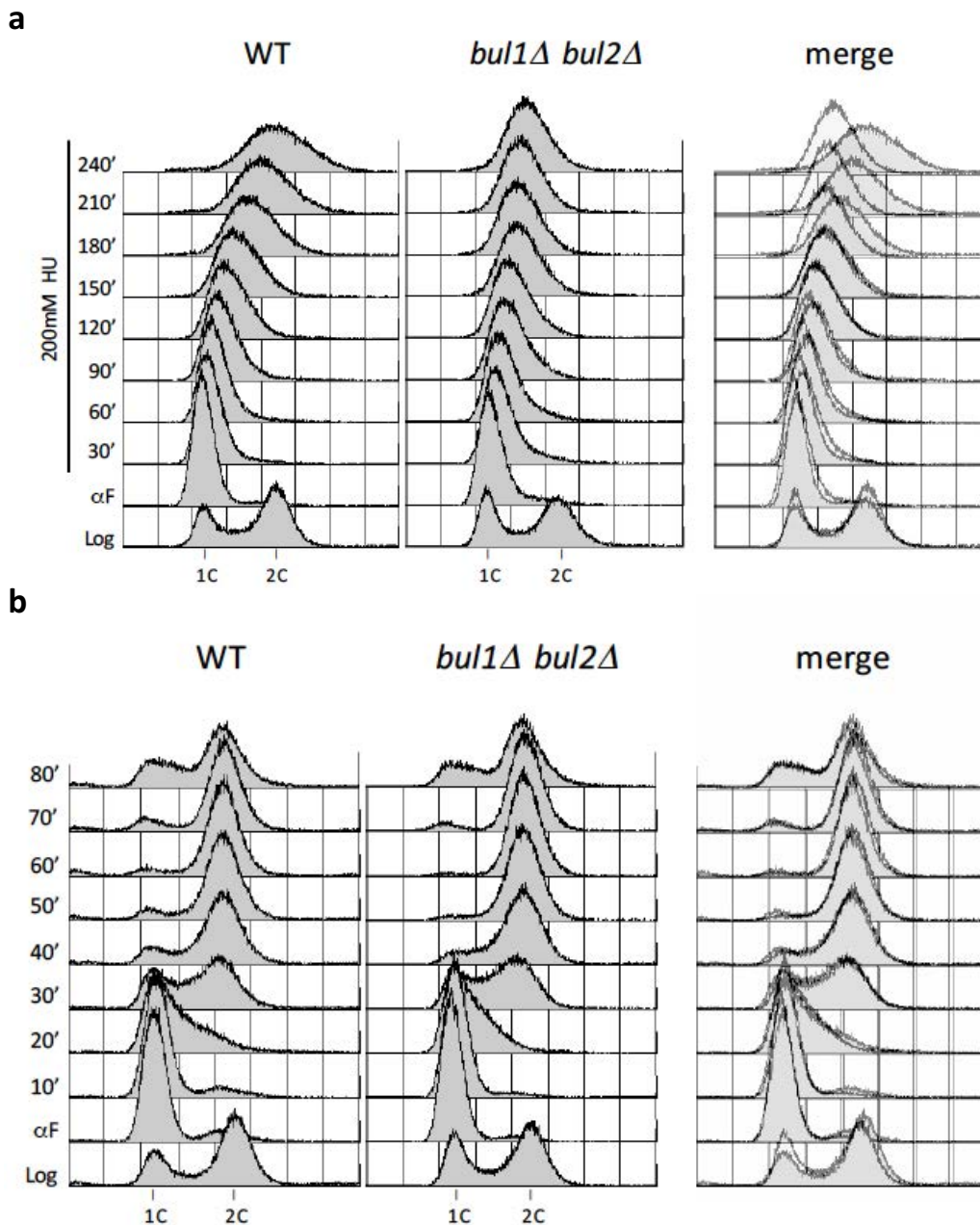

**Figure 3.2. *BUL1 BUL2* double deletion delay cell cycle progression upon replication stress induction by HU treatment.** Logarithmically growing (Log) WT and *bul1Δ bul2Δ* cells were released from G1 ( $\alpha$ F) in fresh YPDA medium (**b**) or in YPDA medium containing 200mM HU (**a**). Samples were taken at the indicated time points for FACS analysis. FACS

profiles were overlapped (merge) to facilitate the comparison of WT and *bul1Δ bul2Δ* cells S-phase progression.

### 3.1.3 Bul2/Rsp5 is involved in the re-start of stalled replication forks.

By FACS analysis we observed DNA replication defects in *bul1Δ bul2Δ* mutant cells experiencing HU-induced replication stress. To investigate how the mutant progressed through S-phase we set up an experimental system that monitored the firing of an early origin and the replication of adjacent DNA regions. We analyzed by neutral/neutral two dimensional gel electrophoresis (2D gels) (Sogo et al., 2002) the firing of the early origin *ARS305* and the progression of replication forks along 15 kilobases towards the centromere. We designed a restriction strategy that allowed visualizing three DNA fragments using probes at *ARS305* or 5 Kbs and 15 Kbs distant to the origin (Fig 3.3a). We synchronized logarithmically growing cells in G1 by  $\alpha$ -factor treatment and released them into a synchronous S-phase in the presence of 200mM HU (3.3c). Under these experimental conditions, after 1 hour in the presence of 200mM HU, both WT and *bul1Δ bul2Δ* replication forks mainly occupied the DNA fragment containing *ARS305* origin (Fig 3.3b). Only few forks were able to progress 5 Kbs after 1-hour treatment with HU. After 2 hours, WT cells were able to re-start replication and efficiently replicated across the 5 Kb region. Fork re-start and subsequent efficient DNA replication is indicated by the progressive disappearance of the *ARS305* signal all along the time points followed by the progressive accumulation of signals in the adjacent DNA regions. After 3-hour treatment with HU WT replication forks moved 15 Kbs, as indicated by signal accumulation in the corresponding region. After 4 hours the analyzed region was completely replicated, as virtually no signal was detected at any of the probed fragments. Differently from WT cells, *bul1Δ bul2Δ* mutant were not able to efficiently re-start replication. Quantification of replication intermediates indicated that roughly half of the forks re-started and progressed 5 Kbs after 2-hour treatment with HU. After 4 hours under replication stress *bul1Δ bul2Δ* cells exhibited forks progressing along entire region (namely at eh *ARS305*, 5 Kb and 15

Kb fragments). The defects in re-starting stalled forks, explain the HU-dependent replication defects of *bul1Δ bul2Δ* mutant seen by FACS analysis.

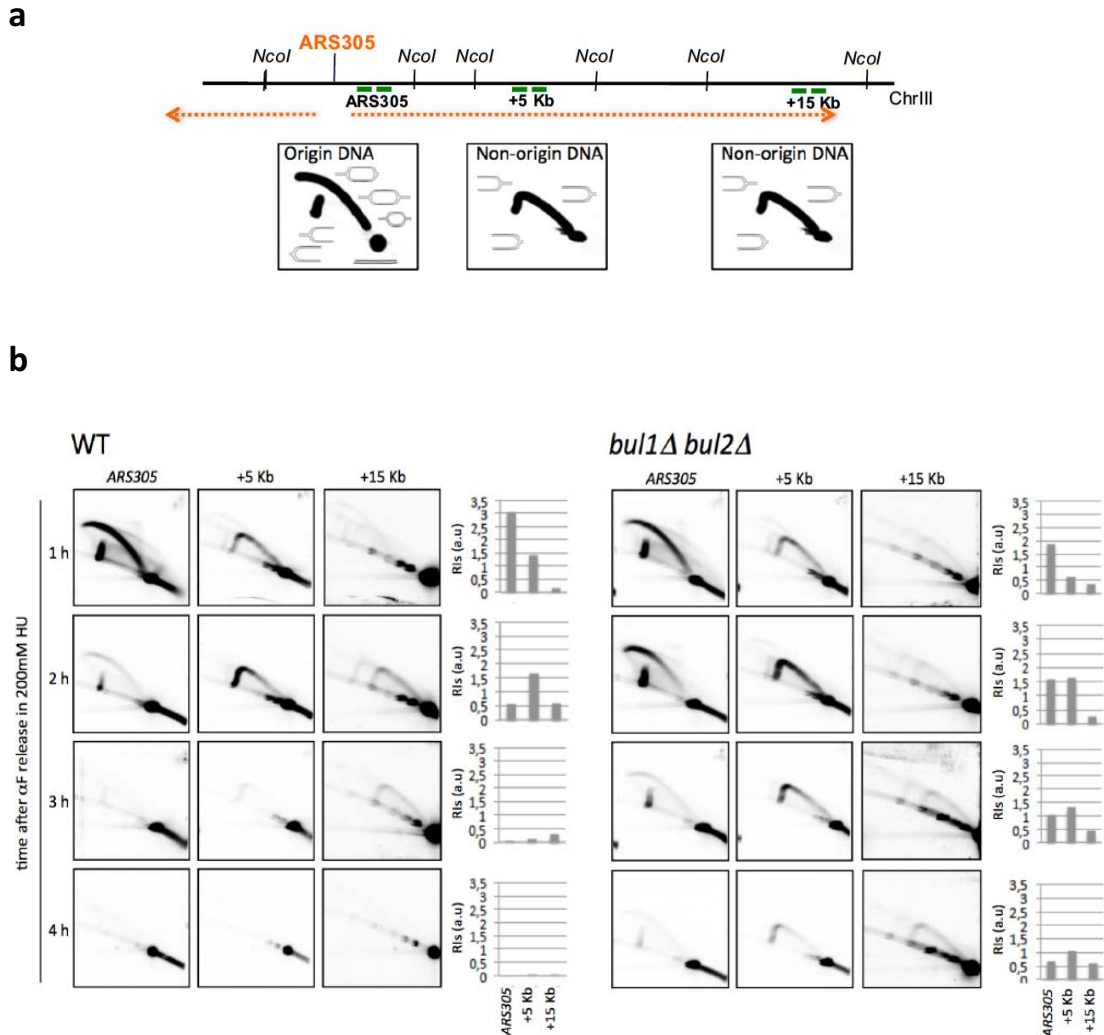

**Figure 3.3. Replication intermediates of WT and *bul1Δ bul2Δ* cells upon replication stress induction by HU treatment.** (a) Schematic representation of the restriction strategy used to analyze replication fork progression by 2D gels. The position of the early origin ARS305 is represented in orange. DNA was digested using *NcoI* enzyme and the fragments were analyzed with specific probes represented in green (see Materials and Methods for details). A schematic drawing of the replication intermediates visualized at each region is shown. (b) Logarithmically growing WT and *bul1Δ bul2Δ* cells were synchronized in G1 and released in the presence of 200mM HU. Samples were collected at the indicated time points and analyzed by 2D gels after genomic DNA extraction. Hybridization with radio-

labeled probes was used to monitor replication fork progression at ARS305, ARS305+5Kbs and ARS305+15Kbs fragments. Quantification of replication intermediates accumulation at the indicated time points is shown. Histograms show the ratio between replication intermediates (bubble + Y arcs) and monomer signals.

To investigate if the fork re-start defects occur throughout the genome in *bul1Δ bul2Δ* mutants, we set up a technique allowing the visualizing fork progression by deep sequencing (Müller et al., 2014). WT and *bul1Δ bul2Δ* cells were synchronously released from a G1 arrest into S-phase in the presence of 200mM HU. Time points were taken in G1 and along S-phase. We monitored replication fork progression by measuring the DNA copy number during S-phase relative to G1-phase. Orange and red bars in each time points represented genomic locations showing ratios higher than 1.2 or 1.5, respectively, in regards to G1 cells. Figure 2.4 represents a region of chromosome I containing two early and efficient replication origins (*ARS108* and *ARS110*) (Shirahige et al., 1998). Full genomic maps are provided in Appendix 1. Both in WT and *bul1Δ bul2Δ* cells, regions flanking *ARS108* and *ARS110* increased their copy number around the origin after 1 hour in S-phase indicating origin firing (Fig 3.4a). At later time points, WT forks moved further away from initiation sites, as indicated by the significantly increased ratios observed up to 4 hours. By contrast, cells ablated for *BUL1* and *BUL2* accumulated discontinuous enrichment tracks after 2 hours of HU treatment indicating severe fork progression defects. Unefficient replication fork re-start in *bul1Δ bul2Δ* cells was observed throughout the genome (Fig 3.4b). Together with the 2D gel data, these results indicate that Bul2/Rsp5 promotes efficient re-start of replication forks stalled by HU-induced DNA synthesis inhibition.

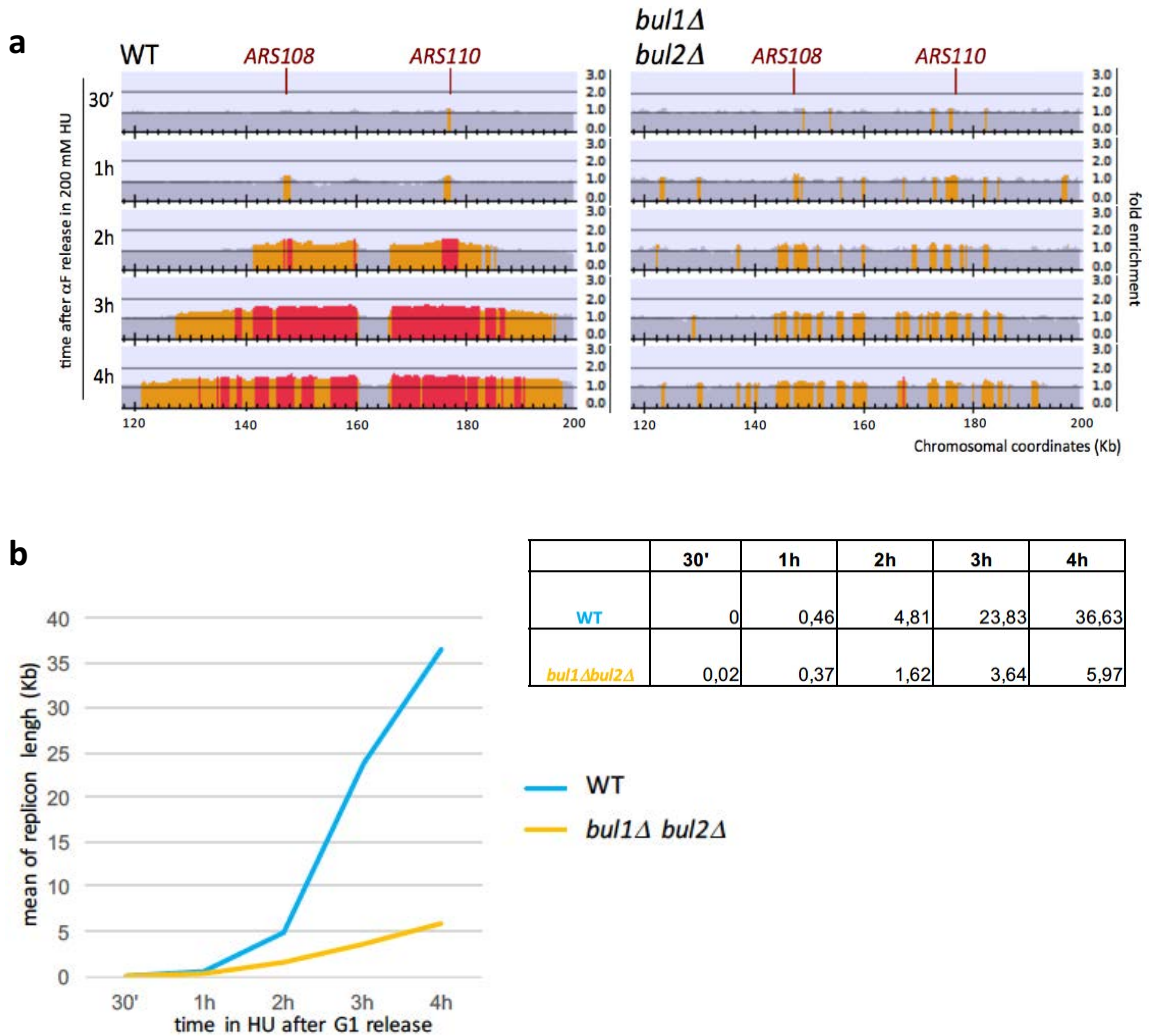
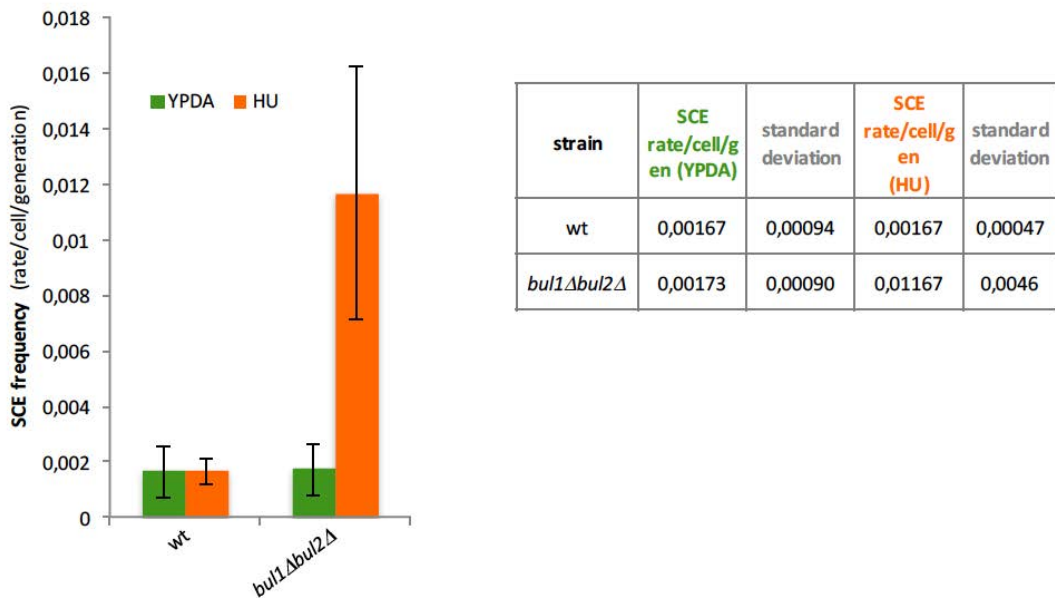

**Figure 2.4. Deletion of *BUL1* and *BUL2* impairs stalled replication fork progression.**

Logarithmically growing WT and *bul1Δ bul2Δ* cells were synchronized in G1 by  $\alpha$ -factor treatment and released into a synchronous S-phase in the presence of 200mM HU. Samples were taken at G1 and at the indicated time points in HU. Genomic DNA was extracted and then deep-sequenced. Histograms representing S-phase to G1 read ratios on a region on chromosome I containing *ARS108* and *ARS110* origins are shown. Orange and red coloured bars note ratios higher than 1.2 or 1.5, respectively. **b)** Average length of early firing replicons in WT and *bul1Δ bul2Δ* cells along the time course. The length of each replicon was calculated counting the kilobases covered by the orange and red coloured bars along the time course. The mean value of early firing replisoms was and plotted in the graph related to the time in HU after G1 release.

#### 3.1.4 Bul2/Rsp5 promotes replication fork stability.

By 2D gels experiments and genome wide sequencing we saw that in the absence of *BUL1* and *BUL2* stalled forks did not efficiently re-start replication. To investigate if replication forks were more unstable in *bul1Δ bul2Δ* cells compared to WT, we took advantage of a genetic system developed by the Symington's laboratory allowing to measure sister chromatid exchange events (SCE) (Mozlin et al., 2008). These events involve the exchange of nucleotide sequences between two identical molecules of DNA. The fact that exchanges between sister chromatids can only occur during S-phase made us calculate recombination events strictly dependent on DNA duplication. To measure SCE events we used a substrate that contains a direct repeat of mutated alleles of the *ade2* gene separated by plasmid sequences and a copy of the *TRP1* gene. The construct was integrated in the *ADE2* locus on chromosome XV (see Material and Methods for details) (Fig. 6.5). Single colonies from WT and *bul1Δ bul2Δ* strains were plated in the presence (orange) or absence (green) of HU concentrations sublethal for *bul1Δ bul2Δ* mutants (20mM HU) (Fig 3.5b). Differently from untreated conditions in which WT and *bul1Δ bul2Δ* cells showed comparable frequencies of sister chromatid exchange events, exposing *bul1Δ bul2Δ* colonies to HU caused a 10-fold increase in the number of SCE events compared to the WT. These data indicate that upon impairment of Bul2/Rsp5 function replication forks are more unstable and prone to replication-dependent recombination events.



**Figure 3.5. Analysis of sister chromatid recombination rates in WT and *bul1Δ bul2Δ* cells.** Single colonies of WT and *bul1Δbul2Δ* cells were plated on SC-Ade medium in the presence (orange) of absence (green) of 20mM HU. Histograms represented the rates of sister chromatid recombination events per cell per generation and their standard deviation; the corresponding values are listed in the table on the right (see Materials and Methods for details).

From the data presented so far we can conclude that Bul2/Rsp5-mediated ubiquitylation events are required to promote efficient and stable replication fork re-start, thus contributing to cell survival to replication stress.

### 3.2 The Bul2/Rsp5 complex is recruited to replication forks.

Since Bul2 confers target specificity to Rsp5 ubiquitin conjugating enzyme, we reasoned that Bul2 could participate in the post-translational modification of factors involved in promoting fork re-start. To investigate our hypothesis, our group searched for physical interactors by Bul2 immunoprecipitation followed by Mass Spectrometry (MS). Noteworthy, among Bul2 interacting proteins we

identified the checkpoint apical kinase Mec1 and two subunits of the cohesin complex, Smc1 and Smc3.

### 3.2.1 Bul2/Rsp5 and Mec1/Ddc2 complexes interact during S-phase.

We first confirmed the interaction between Bul2/Rsp5 and Mec1/Ddc2 complexes identified by MS. For this purpose, we constructed a strain carrying tagged versions of Bul2, Rsp5 (Kamińska et al., 2002) and Ddc2 proteins. Logarithmically growing cells were synchronized in G1 by  $\alpha$ -factor treatment and then released in the presence of 200mM HU. After 1-hour treatment with HU cells were collected and proteins were extracted under native conditions to preserve protein-protein interactions as explained in Materials and Methods. Immunoprecipitation of Bul2-PK and Ddc2-MYC was performed and co-immunoprecipitated proteins were analyzed by Western Blot. As represented in Figure 3.6, immunoprecipitation of Ddc2-MYC by anti-MYC antibody lead to the identification of both Bul2-PK and HA-Rsp5 proteins. Viceversa, by immunoprecipitation of Bul2-PK with anti-PK antibody we were able to detect the E3 Ubiquitin ligase Rsp5 and the Mec1-adaptor protein Ddc2. When immunoprecipitation of Ddc2-MYC and Bul2-PK was performed in the absence of the specific antibody interaction between the two complexes was not identified, indicating that Bul2/Rsp5 specifically interacts with Mec1/Ddc2 complex.

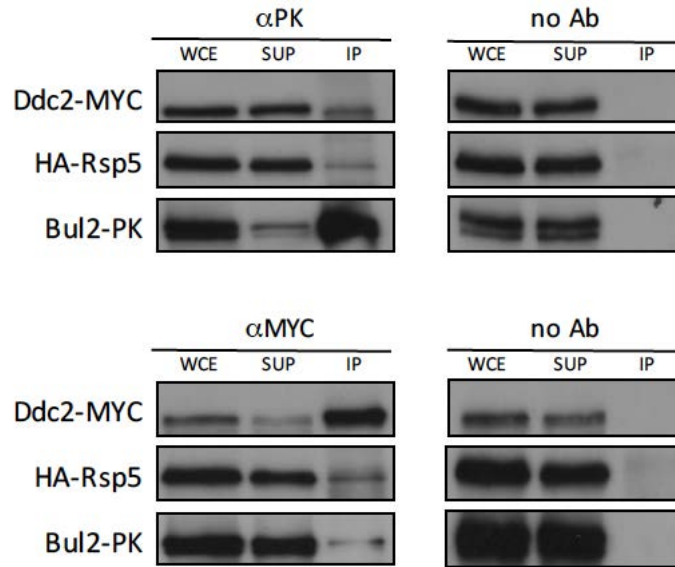

**Figure 3.6. The Bul2/Rsp5 complex interacts with Mec1-Ddc2 in HU-treated cells.** Cells expressing Ddc2-MYC, Bul2-PK and HA-Rsp5 were released from G1 into 200mM HU YPDA medium for 1 h. Protein extracts were subjected to anti-MYC (top) or anti-PK (bottom) immunoprecipitation (IP). Immunoprecipitations in the absence of specific antibodies were performed as controls (no Ab). IP efficiency and co-immunoprecipitated proteins were analyzed by western blotting with the corresponding epitope antibodies. WCE=whole cell extract; SUP=supernatant; IP=immunoprecipitation.

We then investigated if Bul2/Rsp5 interaction with Mec1/Ddc2 was specific to HU-induced replication stress. Cells expressing Bul2-PK, HA-Rsp5 and Ddc2-MYC tagged proteins were released from a G1 block in a synchronous S-phase in the presence or absence of HU. Ddc2-MYC co-immunoprecipitated with HA-Rsp5 and Bul2-PK in extracts from cells replicating both conditions. However, the levels of co-immunoprecipitated Bul2 and Rsp5 proteins were higher in cells experiencing replication stress (Fig 3.7). Similarly, immunoprecipitation of Bul2-PK recovered higher levels of Ddc2 in extracts from cells treated with HU. These data point at a constitutive interaction between Bul2/Rsp5 and Mec/Ddc2 complexes that is somewhat enhanced in cells experiencing replication stress.

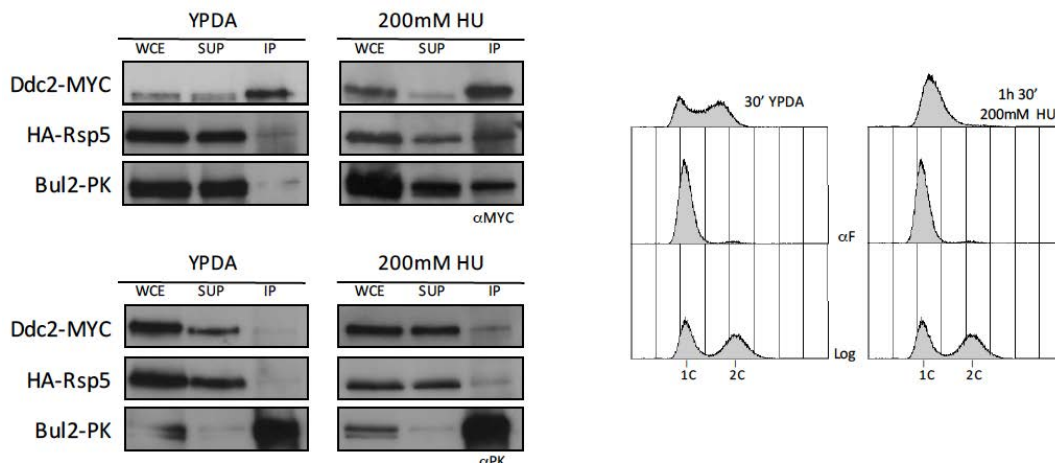

**Figure 3.7. Bul2/Rsp5 and Mec1/Ddc2 interact in S-phase cells.** Cells expressing Ddc2-MYC, Bul2-PK and HA-Rsp5 were synchronized in G1 ( $\alpha$ F) and released in a synchronous S-phase in presence or absence of 200mM HU. S-phase samples were subjected to anti-MYC (top) or anti-PK (bottom) immunoprecipitation (IP). IP efficiency and co-immunoprecipitated proteins were analyzed by western blotting with the corresponding epitope antibodies (left panel). WCE=whole cell extract; SUP=supernatant; IP=immunoprecipitation. FACS analysis (right panel) of the cultures synchronized in the experiment is shown. Log=logarithmically growing cells;  $\alpha$ F=G1 synchronized cells.

Mec1 is the apical kinase that senses replication stress and activates a signaling cascade leading to the stabilization of replication forks and ultimately granting genome integrity. We saw that the interaction between Bul2/Rsp5 and Mec/Ddc2 complexes was increased under conditions of replication stress. We thus investigated if the interaction of the two complexes depended on the activation of Mec1 upon treatment with HU. To this purpose we performed co-immunoprecipitation experiments between Ddc2 and Bul2 in a Mec1 kinase dead background. The *mec1-kd1*-dependent cell lethality is suppressed by deletion of *SML1* gene, similarly to *MEC1* deletion (Paciotti et al., 2001). G1-synchronized *sm11Δ* and *sm11Δ mec1-kd1* cells were released in the presence of 200mM HU. We did not observe relevant differences in the interaction between Bul2 and Ddc2 when either Ddc2-MYC or Bul2-PK was immunoprecipitated in the presence or absence of Mec1 kinase activity (Fig 3.8).

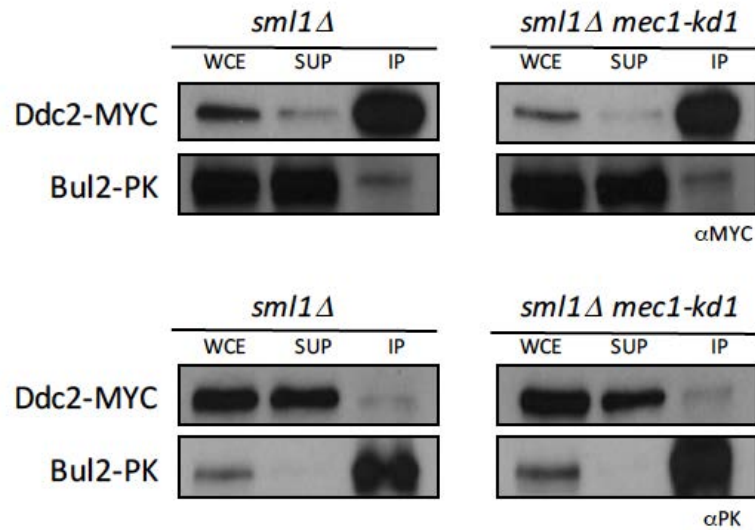

**Figure 3.8. Bul2/Rsp5 and Mec1/Ddc2 interact in a checkpoint-independent manner.** *sm1Δ* and *sm1Δ mec1-kd1* cells expressing Ddc2-MYC and Bul2-PK were released from a G1 arrest into 200mM HU for 1 h. Protein extracts were subjected to an anti-MYC (top) or anti-PK (bottom) immunoprecipitation (IP). IP efficiency and co-immunoprecipitated proteins were analyzed by western blotting with the corresponding epitope antibodies. WCE=whole cell extract; SUP=supernatant; IP=immunoprecipitation.

These results indicate that: i) Bul2/Rsp5 and Mec1/Ddc2 interact during S-phase; ii) Bul2/Rsp5 and Mec1/Ddc2 interaction is enhanced during HU-induced replication stress; and iii) Bul2/Rsp5 interacts with Mec1/Ddc2 in a checkpoint-independent manner.

### 3.2.2 Investigating crosstalk between Bul2/Rsp5 and Mec1/Ddc2 complexes.

We demonstrated the interaction between the Bul2/Rsp5 ubiquitin ligase complex and Mec1/Ddc2 during S-phase. A simple and intuitive explanation for the function of this interaction consists in Mec1/Ddc2 been a ubiquitylation substrate of Bul2/Rsp5. To test this hypothesis, we performed Ni pull-down experiments of Ddc2-MYC from WT and *rsp5-25* cells expressing a HIS-tagged ubiquitin under the

*CUP1* copper regulatable promoter.  $\alpha$ -factor synchronized cells were released from G1 into S-phase in the presence of 200mM HU. HIS-tagged ubiquitin was expressed throughout the experiment by the addition of copper sulphate ( $\text{CuSO}_4$ ) to -URA synthetic medium. We were not able to detect any Rsp5-dependent ubiquitylation forms of Ddc2 (Fig 3.9) or Mec1 (from our laboratory). These results suggest that the Mec1/Ddc2 complex is not targeted by Bul2/Rsp5 for ubiquitylation.

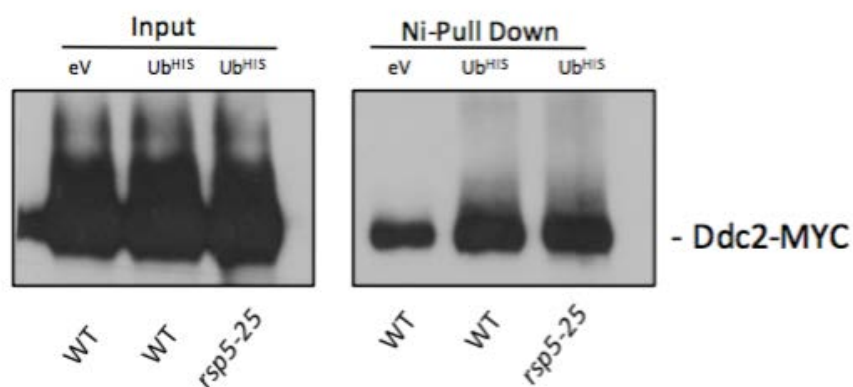
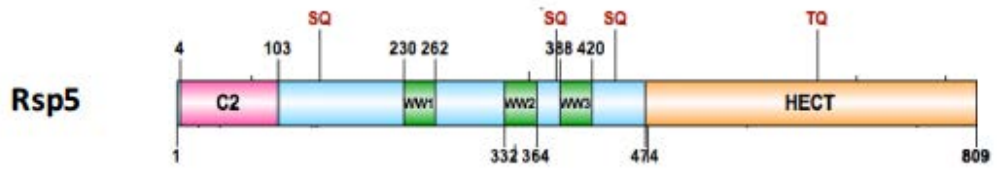
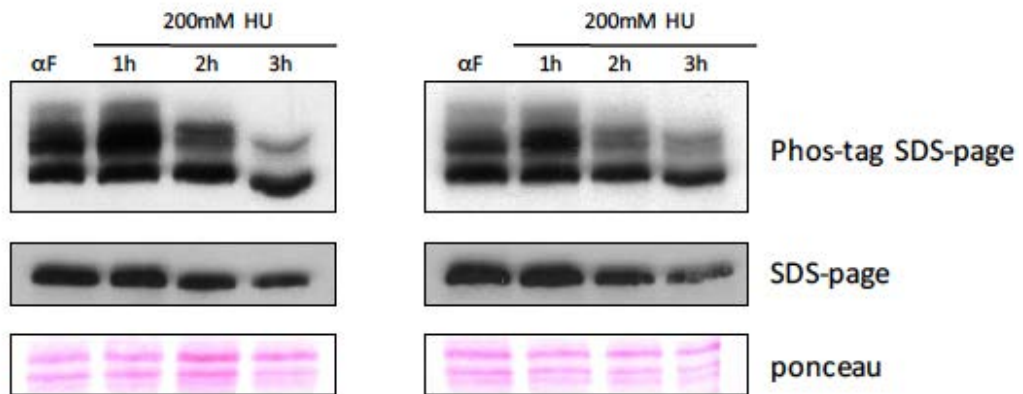

**Figure 3.9. Ni-pull down ubiquitylation assays of Ddc2 in HU treated cells.** WT and *rsp5-25* cells expressing Ddc2-MYC and carrying *YEplac195-CUP1* (eV) or *YEplac195-CUP1-HIS7-UB* (Ub) vectors were synchronized in G1 by  $\alpha$ -factor in 200mM HU. Samples were taken after 2 hours for Ni Pull Down and Immunodetection of Ddc2 by MYC antibody.

Both Rsp5 and Bul2 peptidic sequences contain SQ/TQ sites that consensus for phosphorylation by Mec1 (Traven & Heierhorst, 2005). It is therefore reasonable to think that Mec1 could influence the ubiquitin ligase complex Bul2/Rsp5 activity through phosphorylation of its components. To test this hypothesis, we constructed checkpoint deficient strains (*mec1 $\Delta$  tel1 $\Delta$  sml1 $\Delta$* ) expressing tagged versions of Rsp5 or Bul2. We set up specific conditions to analyze the phosphorylation state of HA-Rsp5 and Bul2-PK using Phos-tag gels as described in Materials and Methods. Phos-tag gels specifically separate proteins based on their

phosphorylation status. Cells were synchronized in G1 by  $\alpha$ -factor treatment and then released into a synchronous S-phase in the presence of 200mM HU (Fig 3.10). Samples were taken at the indicated time points and proteins were extracted under denaturing conditions. We detected hyper-phosphorylated Rsp5 and Bul2 both in G1 and in S-phase under replication stress. However, these phospho-isoforms of Rsp5 and Bul2 were not dependent on checkpoint kinases. These data indicate that the Bul2/Rsp5 complex is phosphorylated in a Mec1-independent manner. Moreover, our data suggest that crosstalk between Bul2/Rsp5 and Mec1/Ddc2 complexes does not occur through reciprocal post-translational modifications.

a

*HA-Rsp5 sml1Δ**HA-Rsp5 sml1Δ mecl1Δ tel1Δ*

b

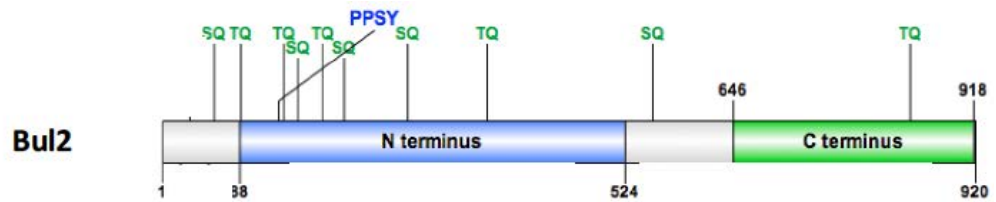
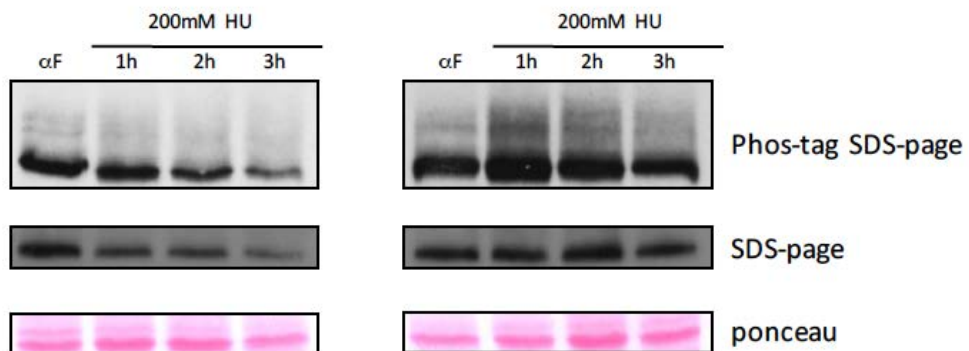
*Bul2-PK sml1Δ**Bul2-PK sml1Δ mecl1Δ tel1Δ*

**Figure 3.10. Phos-tag gel analysis of Rsp5 and Bul2 phosphorylation.** *sm11Δ* and *sm11Δmec1Δ tel1Δ* cells expressing HA-Rsp5 (a) or Bul2-PK (b) were released from G1 ( $\alpha$ F) into 200mM HU containing medium. TCA protein extracts were collected at the indicated time points and analyzed in a SDS-page in the presence or absence of the Phos-tag ligand. HA-Rsp5 and Bul2-PK were immunodetected with the corresponding antibodies. Ponceau S staining is presented as loading control. Possible Mec1-dependent SQ and TQ sites are shown on schematic representations of Rsp5 and Bul2 aminoacid sequence in brown and green, respectively. The Rsp5-interacting PPSY motif is indicated on Bul2 sequence (blue).

### 3.2.3 The Bul2/Rsp5 complex is recruited to stalled replication forks.

We were not able to detect Mec1 or Ddc2 ubiquitylation forms, nor Mec1-dependent phosphorylation of Bul2 or Rsp5. Mec1 is recruited by its regulatory subunit Ddc2 ssDNA excessively accumulating at sites where replication forks stall. The physical interaction between Bul2/Rsp5 and Mec1/Ddc2 complexes may therefore imply the recruitment of ubiquitin ligase complex to replication forks upon stalling by HU treatment. To test this hypothesis, we investigated the genomic distribution of Bul2 by CHIP-chip. Cells expressing Bul2-PK and Ddc2-MYC tagged proteins were synchronized in G1-phase by  $\alpha$ -factor and then synchronously released into S-phase in the presence of 200mM HU. Each protein was crosslinked to DNA and immunoprecipitated using the specific antibody. DNA fragments immunoprecipitated with Bul2-PK or Ddc2-MYC were then hybridized on DNA microarrays, thus identifying the specific protein binding regions. Under these experimental conditions Ddc2 enrichment was observed at different genomic locations including regions containing stalled replication forks emanated from early origins such as *ARS314* and *ARS315* (Fig 3.11). Consistently, at sites of replication fork stalling Bul2 enrichment overlapped with that of Ddc2.

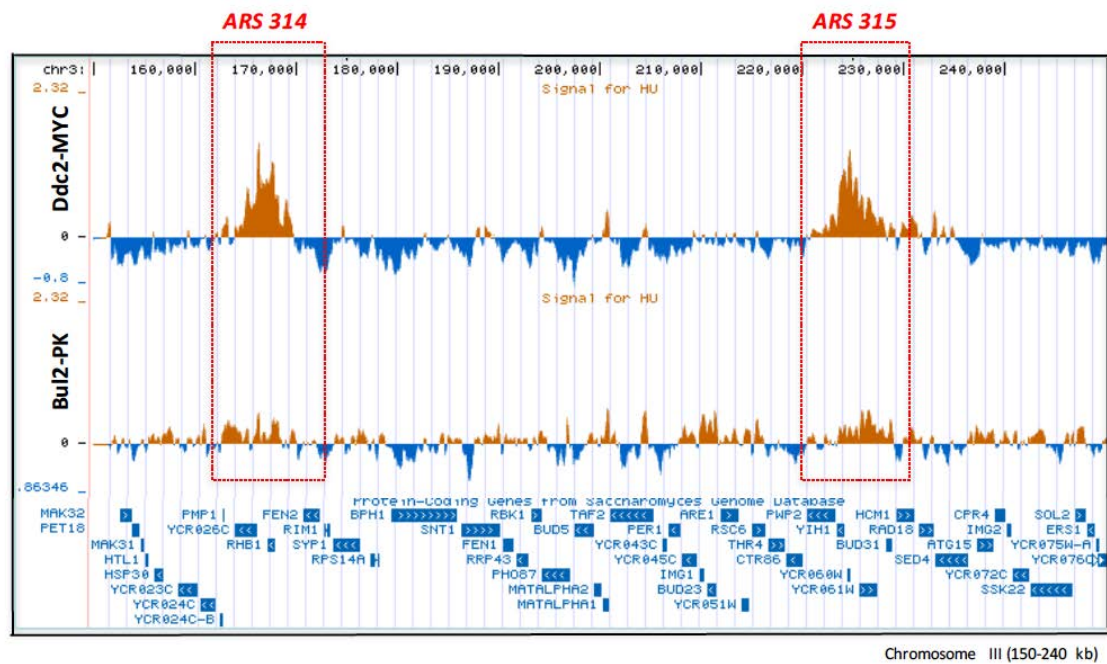

**Figure 3.11. Bul2 colocalizes with Ddc2 at stalled replication forks.** Logarithmically growing cells expressing Ddc2-MYC and Bul2-PK were synchronized in G1 by  $\alpha$ -factor and released for 1 hour in the presence of 200mM HU. Proteins were crosslinked to chromatin and immunoprecipitated with anti-MYC and anti-PK antibodies. Orange histogram bars in the y axis show the average signal ratio in log2 scale of loci along the reported region on chromosome III. The x axis shows chromosomal coordinates. Positions of early ARS elements are painted in red. Replication origin and ORFs sequences are indicated in blue in the bottom part of the panel.

We conclude from this analysis that Bul2/Rsp5 and Mec1/Ddc2 complexes interact during S-phase and co-localize at stalled replication forks. We hypothesize that physical interaction with Mec1/Ddc2 mediates the localization of the Rsp5/Bul2-mediated ubiquitination to stalled forks where it may modulate specific target(s) to promote fork re-start.

### **3.3 The Bul2/Rsp5 complex promotes cohesin-mediated replication fork re-start.**

#### **3.3.1 Bul2/Rsp5 physically interacts with cohesin subunits Smc1 and Smc3.**

As previously mentioned, among Bul2 interactors identified by MS we also found the cohesin complex subunits Smc1 and Smc3. We scored the interaction between Bul2/Rsp5 complex and the cohesin subunits Smc1 and Smc3 by co-immunoprecipitation experiments. Logarithmically growing cells were synchronized in G1 by  $\alpha$ -factor treatment and then released in the presence of 200mM HU. Protein extracts were used for immunoprecipitation of Bul2-FLAG, Smc1 or Smc3 tagged with PK. Co-immunoprecipitated proteins were analyzed by Western Blot. As represented in Figure 3.12a, anti-FLAG immunoprecipitation of Bul2 enriched for both HA-Rsp5 and Smc3-PK proteins. Viceversa, immunoprecipitation of Smc3-PK enriched for both components of the Bul2/Rsp5 complex (Figure 3.12b). Analogously, Smc1-PK co-immunoprecipitated Bul2-PK and HA-Rsp5 in cells treated with HU. These data indicate that Bul2/Rsp5 physically interacts with Smc1 and Smc3 cohesin complex subunits in cells experiencing replication stress.

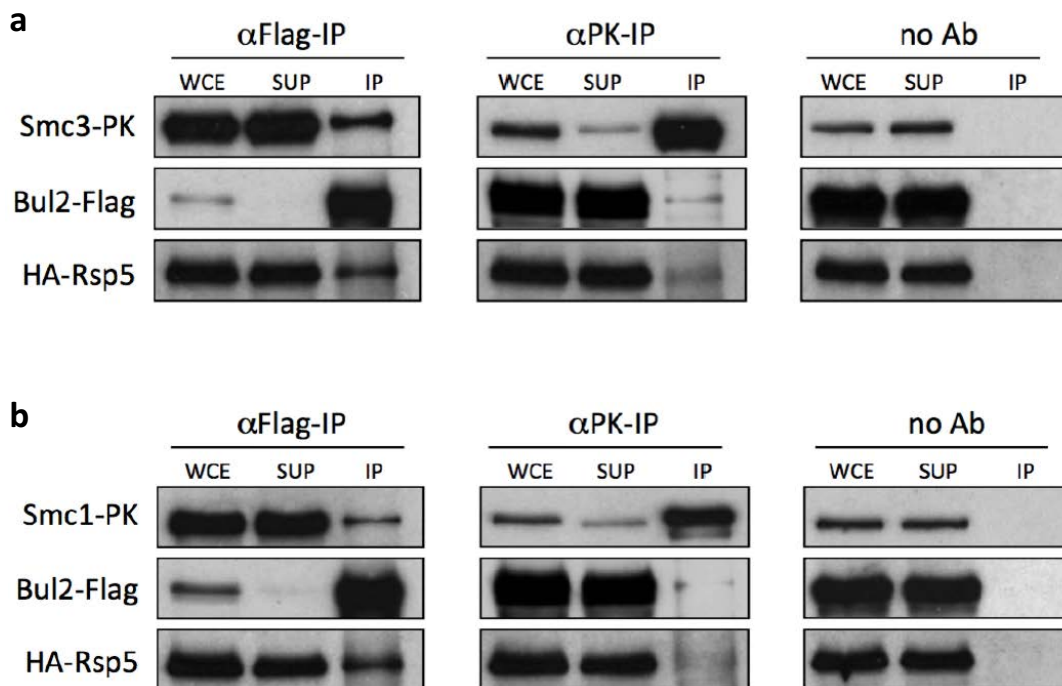
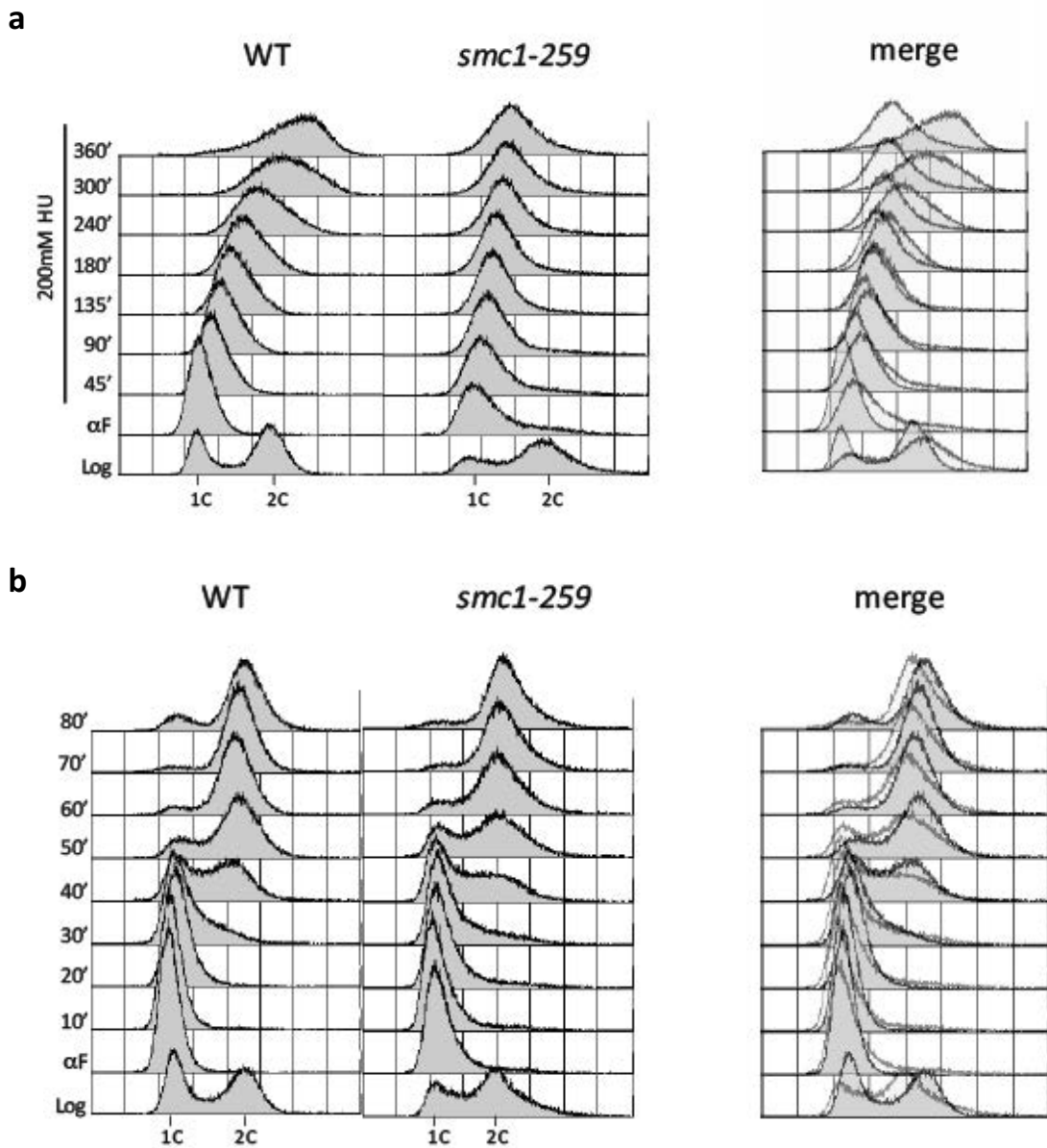

**Figure 3.12. Bul2/Rsp5 interacts with the Smc3 and Smc1 subunits of the cohesin complex.** Cells expressing Smc3-PK (a) or Smc1-PK (b) along with Bul2-Flag and HA-Rsp5 were released from G1 into 200mM HU. Protein extracts were subjected to anti-Flag or anti-PK immunoprecipitation (IP). Immunoprecipitation in the absence of a specific antibody (no Ab) was performed as control. IP efficiency and Co-immunoprecipitated proteins were analyzed by western blotting with the corresponding epitope antibodies. WCE=whole cell extract; SUP=supernatant; IP=immunoprecipitation.

### 3.3.2 Cohesin complex is required for the re-start of replication forks stalled by dNTP pools depletion.

It has been recently reported by the Pasero's group (Tittel-Elmer et al., 2012) that cohesin accumulates to at replication forks and facilitates the re-start of forks replicating damaged DNA templates. It was proposed that cohesion exerts this function by maintaining sister chromatids in a conformation that favors fork re-start. In particular, they observed replication progression defects in *scc1-73* mutant cells upon MMS treatment.

We first investigated if cohesin role in promoting fork-restart is extensible to other types of replication stress. For this, we monitored DNA synthesis by FACS analysis comparing WT and *smc1-259* cells synchronously released from a G1 block into S-phase in the presence of 200mM HU (Fig 3.13a). WT cells slowly reached a 2C DNA content along the 6-hour time course, while *smc1-259* mutants only slightly increased their DNA content. In contrast, *smc1-259* cells released from a G1 block into medium without drugs efficiently replicated DNA with kinetics comparable to those of WT cells (Fig 3.13b)



**Figure 3.13. *smc1-259* mutation delays S-phase progression upon HU-induced replication stress.** Logarithmically growing (Log) WT and *smc1-259* cells were released from G1 ( $\alpha$ F) in medium containing 200mM HU (a) or medium without drug (b). Samples were taken at the indicated time points for FACS analysis. FACS profiles were overlapped (merge) to facilitate the comparison of WT and *smc1-259* mutant cell cycle progression.

We then addressed the role of cohesin in the re-start of HU-mediated stalled replication forks. To this purpose we took advantage of the 2D strategy developed to analyze replication dynamics in *bul1 $\Delta$  bul2 $\Delta$*  cells (Fig. 3.14a). Logarithmically growing cells were released from a G1 block induced by  $\alpha$ -factor treatment into a synchronous S-phase in the presence of 200mM HU at the semipermissive temperature for the *scm1* allele of 34 °C. Samples were taken after 45, 90, 135 and 180 minutes. After 45 minutes, both WT and *smc1-259* cells accumulated most of replication forks at the *ARS305* early origin fragment (Fig 3.14b). Few forks were able to progress 5 Kb from the fired origin in WT, but not *smc1-259*, cells. After 90 minutes forks re-started replication and efficiently progressed through the fragment analyzed, and were mainly detected at the +15 Kb fragment by 3 hours in wild type cells. Efficient re-start and replication progression is inferred from the gradual disappearance of the *ARS305* signal throughout the time course accompanied by the progressive accumulation and subsequent decrease of replication intermediates in the adjacent DNA regions. Differently from WT cells, after 90 minutes in the presence of HU forks were not able to efficiently re-start replication in *smc1-259* mutants. A majority of the forks lagged at *ARS305* by 90 minutes and after 135 minutes barely half of the forks had progressed into the +5 Kb fragment. After 3 hours under replication stress *smc1-259* cells exhibited forks stalled throughout the analyzed regions to roughly equivalent levels.

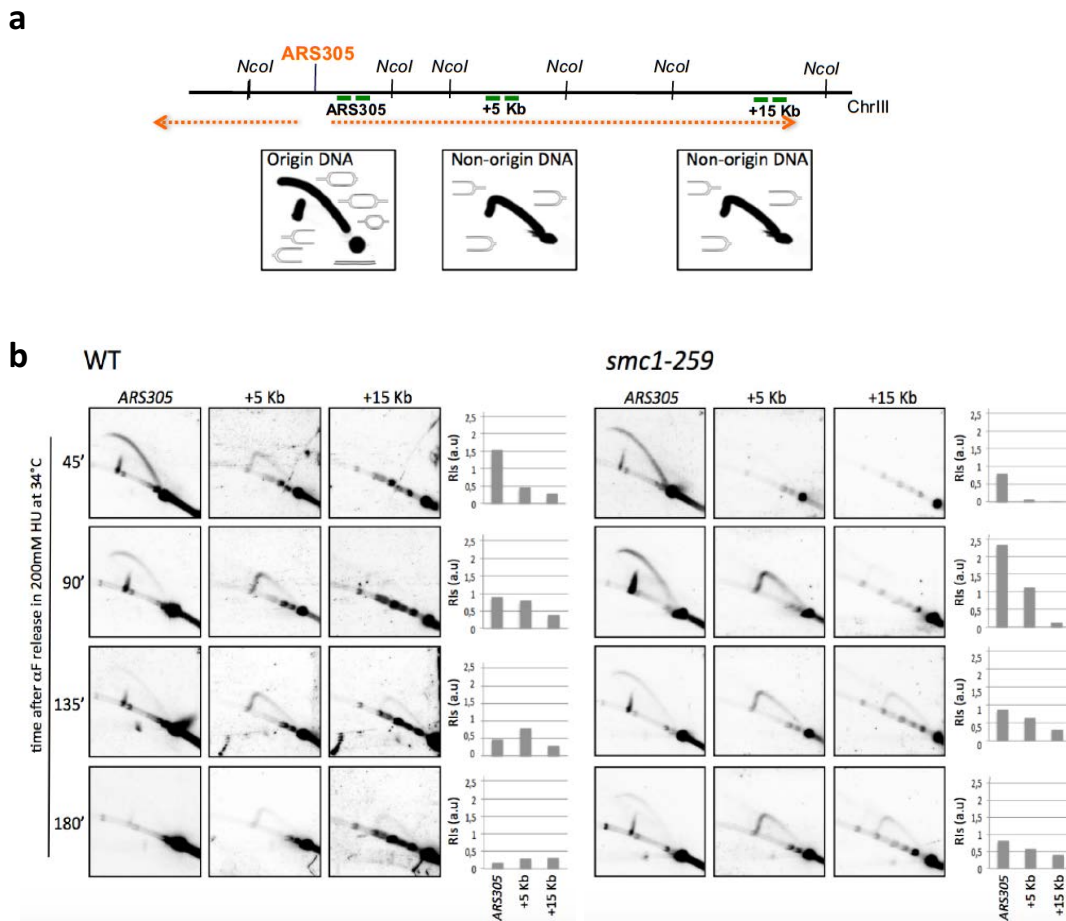

**Figure 3.14. 2D gel analysis of stalled fork progression in WT and *smc1-259* cells. (a)** Schematic representation of the restriction strategy used to analyze replication fork progression by 2D gels. The position of the early origin *ARS305* is represented in orange. DNA was digested using *NcoI* enzyme and the fragments were analyzed with specific probes represented in green. A schematic drawing of the replication intermediates visualized at each region is shown. **(b)** Logarithmically growing WT and *smc1-259* cells were synchronized in G1 at 25°C and released in YPDA medium at 34°C in the presence of 200mM HU. Samples were collected at the indicated time points. Genomic DNA was extracted and analyzed by 2D gels. Hybridization with radiolabeled probes was used to monitor replication fork progression at *ARS305*, *ARS305+5Kb* and *ARS305+15Kb* fragments. Quantification of replication intermediates accumulation at the indicated time points is shown. Histograms show the ratio between replication intermediates (bubble + Y arcs) and monomer signals.

Moreover, we analyzed by deep sequencing the replication defects in cohesin defective cells. As described for *bul1Δ bul2Δ* mutants, WT and *smc3-42* cells were synchronized in G1 by  $\alpha$ -factor and then released into S-phase in the presence of 200mM HU. Samples were taken at G1-phase and at 30 minutes, 1, 2, 3 and 4 hours following release in HU. Replication fork progression was inferred by the increase in the fold enrichment of DNA reads during S-phase time points relative to G1-cells. As is exemplified in a chromosomal region containing the early origins *ARS305* and *ARS306*, after 1-hour in HU both WT and *smc3-42* cells duplicated chromosomal regions around *ARS305* and *ARS306* origins (Fig 3.15a), indicative of origin firing. As S-phase advanced in the presence of replication stress, forks steadily progressed away from initiation sites in wild type cells, as indicated by the continuous extension of the coloured bars during the time course. By 4 hours WT cells replicated an average of 179,7 Kbs away from origin sequences. *smc3-42* mutants fire replication origins with dynamics comparable to those of WT cells. However, forks in *smc3-42* cells showed slower progression especially after 2 and 3 hours treatment with HU. Fork progression defects in *smc3-42* cells were observed through the genome, as presented in Figure 3.15b.

**a**

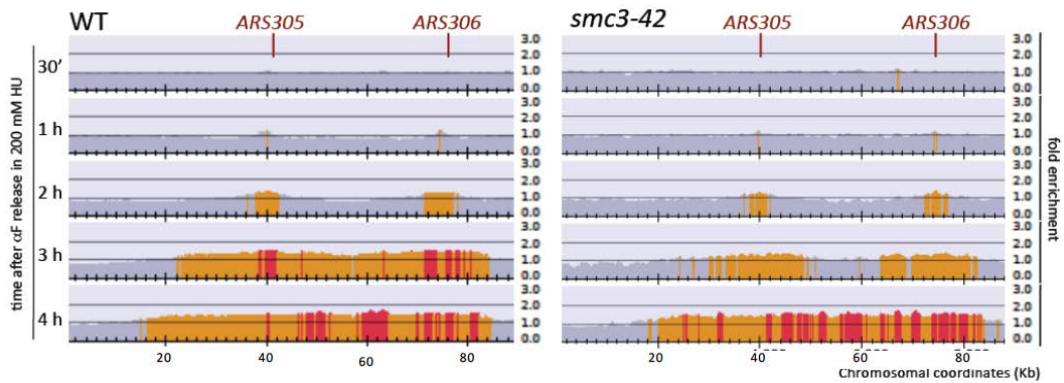

**b**

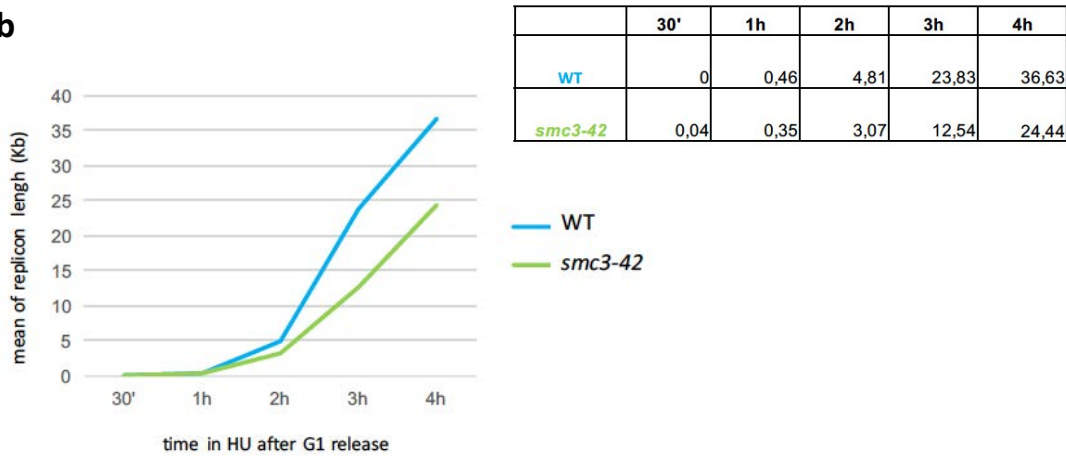

**Figure 3.15. *smc3-42* mutants show defects in replication fork progression.** (a) Logarithmically growing WT and *smc3-42* cells were synchronized in G1 by  $\alpha$ -factor and released into a synchronous S phase in the presence of 200mM HU. Samples were taken at the indicated time points. Genomic DNA was extracted and deep sequenced. Histograms representing S-phase to G1 read ratios on a chromosome III region containing *ARS305* and *ARS306* origins. Orange and red coloured bars note ratios higher than 1.2 or 1.5, respectively. (b) Average length of early firing replicons in WT and *smc3-42* cells along the time course. The length of each replicon was calculated counting the kilobases covered by the orange and red coloured bars along the time course. The mean value of early firing replicons was calculated and plotted in the graph related to the time in HU after G1 release.

These results evidence that cohesin functions to promote the re-start of forks stalled due to DNA synthesis inhibition induced by dNTP shortage.

### 3.3.3 Bul2/Rsp5 stimulates cohesin function in replication fork re-start.

We have demonstrated that cohesin is required for replication fork re-start upon HU-induced replication stress and found that cohesin subunits Smc1 and Smc3 interact with Bul2/Rsp5 ubiquitin ligase complex. Results from the group also demonstrated that *smc3-42* and *smc1-239* alleles are epistatic to *bul1Δ bul2Δ* for HU sensitivity. Moreover, a systematic analysis of cohesin subunits ubiquitylation performed in the laboratory revealed that Smc1, Smc3 and Scc1, but not Scc3, subunits are ubiquitylated upon HU treatment in a Bul2/Rsp5-dependent manner. Lastly, data from the lab evidenced that deletion of *UBP2* gene suppresses the HU sensitivity of *smc3-42* mutant, suggesting that an increase in Rsp5-dependent ubiquitylation is beneficial for cohesion function in response to replication stress. Altogether these data allow us to conclude that: i) cohesin and Bul2/Rsp5 function inside a genetic pathway promoting survival to replication stress; ii) Bul2/Rsp5 likely works upstream of the cohesin complex to stimulate its function in replication stress.

We thus scored for interactions in the replication defects in mutants of these complexes. We first analyzed bulk genome duplication of WT, *bul1Δ bul2Δ*, *smc1-259* and *smc1-259 bul1Δ bul2Δ* cells released from a G1 block by  $\alpha$ -factor into 200mM HU at semipermissive temperature for the cohesion allele. In contrast to WT cells were able to slowly but steadily increase their DNA content along the time course, as described above *bul1Δ bul2Δ* and *smc1-259* cells showed a severely reduced replication (Fig 3.16). Of note, *smc1-259* and *smc1-259 bul1Δ bul2Δ* showed equivalent replication profiles indicating that the functions of Rsp5/Bul2 and cohesion complexes in promoting replication under stressed conditions overlap.

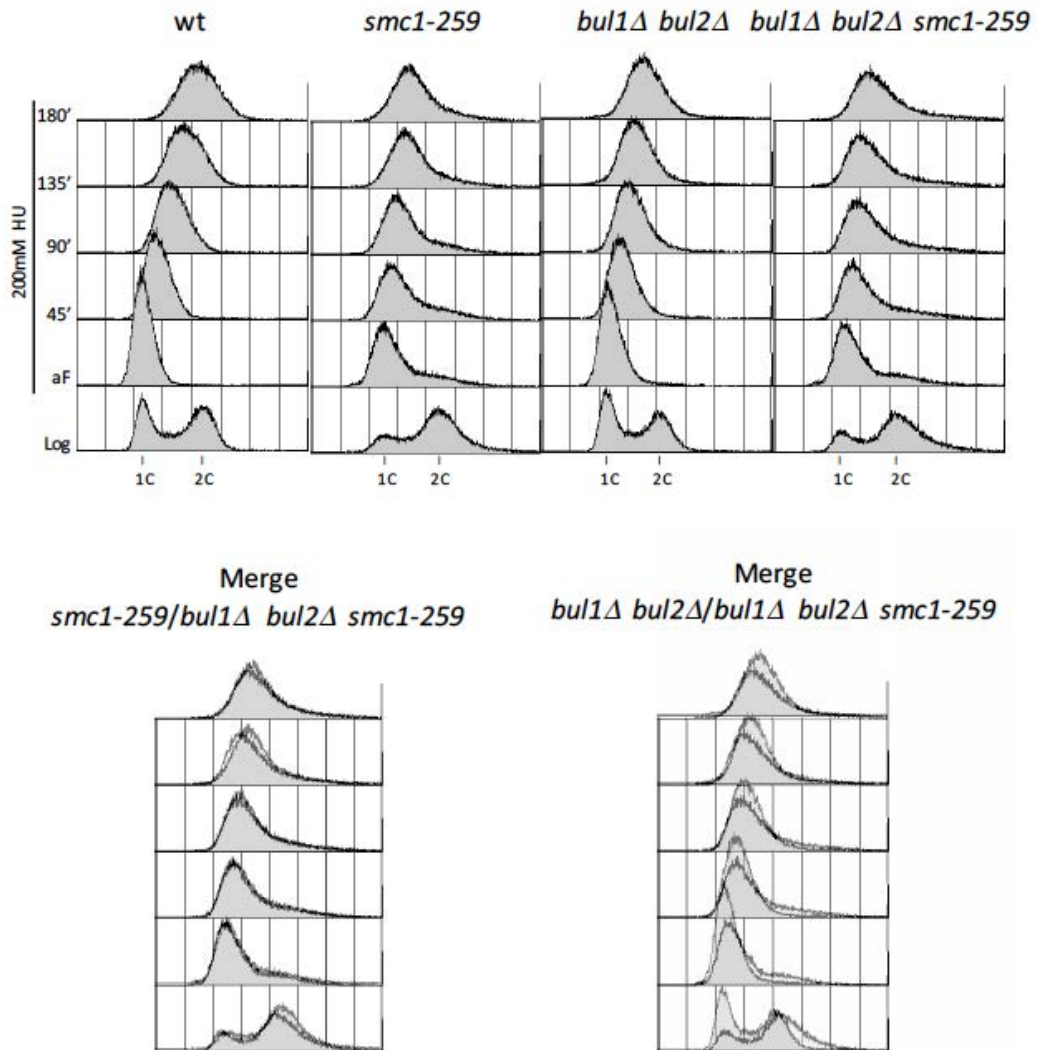

**Figure 3.16. FACS profiles analysis of *smc1-259 bul1Δ bul2Δ* cells upon HU-induced replication stress.** Logarithmically growing (Log) WT, *smc1-259*, *bul1Δ bul2Δ* and *smc1-259 bul1Δ bul2Δ* cells were released from G1 ( $\alpha$ F) in medium containing 200mM HU. Samples were taken at the indicated time points for FACS analysis. FACS profiles were overlapped (merge) to facilitate the comparison of the mutants' cell cycle progression in the presence of replication stress.

We analyzed replication fork re-start in detail by 2D gel electrophoresis in WT, *bul1Δ bul2Δ*, *smc1-259* and *smc1-259 bul1Δ bul2Δ* cells using the same strategy described above. Logarithmically growing cells were synchronously released from

G1 into S-phase in the presence of 200mM HU at 34°C. Samples were taken after 45, 90, 135 and 180 minutes. In WT cells, replication forks progressively left the *ARS305* fragment, resulting in an increase of replication intermediate signals at +5 Kb and +15 Kb fragments by 90 and 135' minutes, and by 180' a small fraction of forks traversed distal regions (Fig 3.17). *smc1-259* and *bul1Δ bul2Δ* cells exhibited stalled fork re-start defects as shown previously, evidenced by the persistence of intermediate signals at *ARS305* fragment throughout the time course and a general failure of replication forks in reaching the +15 Kb region. Notably, replication patterns of *smc1-259 bul1Δ bul2Δ* triple mutant cells mirrored those of *smc1-259* indicating that impairment of Rsp5/Bul2 function has little impact on fork re-start in cells in which cohesin is defective.

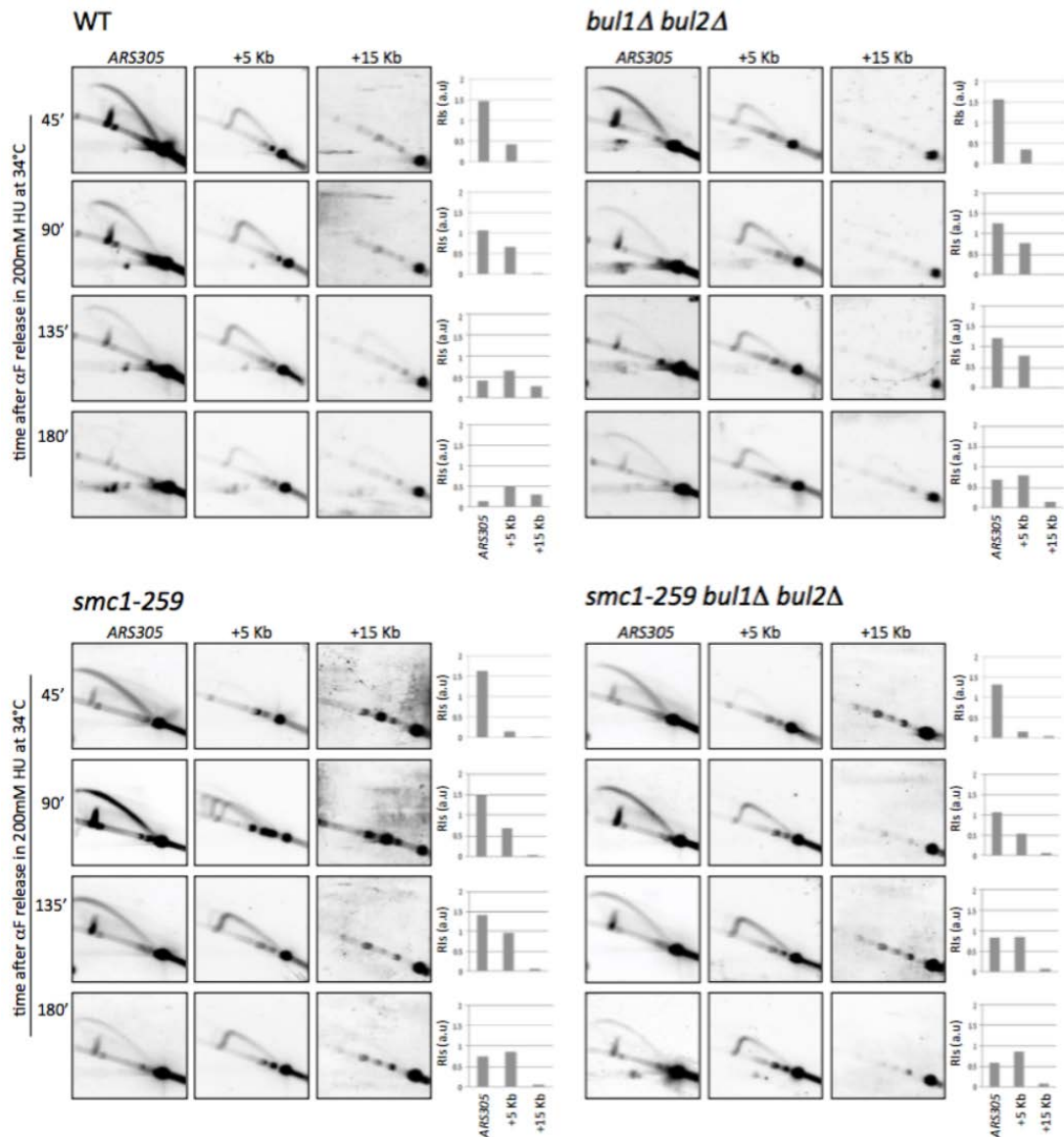

**Figure 3.17. 2D gel analysis of stalled fork progression in WT, *bul1Δ bul2Δ*, *smc1-259* and *bul1Δ bul2Δ smc1-259* cells.** (a) Schematic representation of the restriction strategy used to analyze replication fork progression by 2D gels. The position of the early origin *ARS305* is represented in orange. DNA was digested using *NcoI* enzyme and the fragments were analyzed with specific probes represented in green (see Materials and Methods for details). A schematic drawing of the replication intermediates visualized at each region. Is shown. (b) Logarithmically growing WT and *bul1Δ bul2Δ* cells were synchronized in G1 at 25°C and released at 34°C in the presence of 200mM HU. Samples were collected at the

indicated time points and analyzed by 2D gels after genomic DNA extraction (see Materials and Methods for details). Hybridization with radio-labeled probes was used to monitor replication fork progression at ARS305, ARS305+5Kbs and ARS305+15Kbs fragments. Quantification of replication intermediates accumulation at the indicated time points is shown. Histograms show the ratio between replication intermediates (bubble + Y arcs) and monomer signals.

Collectively, the data obtained in this study evidence that Bul2/Rsp5 and cohesin act on a single pathway promoting stalled fork progression and that ubiquitylation by the ligase complex like stimulates a yet poorly characterized function of cohesin in promoting replication fork stability.



## 4. Discussion

In this work we characterized a novel function for the HECT-E3 ubiquitin ligase Rsp5 and its adaptor Bul2 in the cellular response to replication stress. Cells impaired for *bul2* and *rsp5* function are sensitive to HU-induced replication stress. This correlates with S-phase completion defects due to impaired replication fork re-start. Bul2/Rsp5 physically interacts with the Mec1/Ddc2 checkpoint kinase and this interaction likely drives Bul2/Rsp5 activity to stalled replication forks. We also found a physical interaction between Bul2/Rsp5 and cohesin subunits. Bul2/Rsp5 and the cohesin complex interface and we hypothesise that Bul2/Rsp5 stimulates cohesin function in the process of replication fork re-start. Consistently, data from the laboratory demonstrated that cohesin is ubiquitylated upon HU treatment in a Bul2/Rsp5-dependent manner. We thus propose that the ubiquitin ligase complex mediated cohesin ubiquitylation to promote stalled fork re-start.

Rsp5 has been involved in different nuclear processes like the degradation of the single-stranded-DNA binding protein Rfa1 (Erdeniz & Rothstein, 2000), of the large subunit of RNA polymerase II Rpb1 (Huibregtse et al., 1997), and in the ubiquitin-dependent regulation of the mRNA nuclear export factor Hpr1 (Gwizdek et al., 2005). In this work we show that Rsp5 participates in the response to replication stress. This novel function is mediated through its adaptor Bul2. Bul2 and its paralog Bul1 have been proposed to play overlapping functions in different processes related to receptor internalisation dependent on Rsp5-mediated ubiquitylation (Andoh et al., 2000; Crespo et al., 2004; Kaida et al., 2003; Yashiroda et al., 1998). At least in the response to replication stress these adaptors would not be interchangeable as single deletion of *BUL2* leads to replication stress related phenotypes. These are exacerbated upon additional deletion of *BUL1*, suggesting that even if Bul2 is the preferred adaptor, Bul1

can take over some functions in its absence. Recently, the existence of a third BUL-related adaptor Bul3 has been proposed (Novoselova et al., 2012). *BUL3* gene has a cryptic stop codon that leads to the production a short version of the protein bearing Rsp5-interaction motifs. It was hypothesized that expression of this short Bul3 version may regulate Rsp5 function by competing for the binding for Bul1 and Bul2 adaptors. It would be interesting to investigate the involvement of Bul3 in the response to replication stress.

The fundamental role of Bul2/Rsp5 complex in promoting the viability of cells experiencing replication stress is more likely stabilizing replication forks stalled upon dNTPs depletion and thus permitting the timely completion of chromosome duplication. We hypothesise that the function of Bul2/Rsp5 in the survival to replication stress involves the poly-ubiquitylation of factors implicated in replication fork stabilization. This hypothesis is supported by the observation that ablation of the Ubp2 ubiquitin protease (Kee et al., 2005; Lam & Emili, 2013; Lam, 2010), which removes Rsp5-dependent ubiquitin chains, suppresses *bul2* deletion sensitivity to HU. We carried out a mass spectrometric analysis of Bul2 interactors aimed at identifying potential targets of Bul2/Rsp5 in the response to replication stress. While we failed to observe ubiquitylated Ddc2 or Mec1, a fraction of the cohesion subunits Smc1, Smc3 and Scc1 was ubiquitylated in a Bul2/Rsp5-dependent manner in HU-treated cells (data from the laboratory). Our data do not discriminate whether cohesin is a direct target for Rsp5 or additional ligases are involved. Cohesin is enriched at genomic regions undergoing replication (Lengronne et al., 2004; Tittel-Elmer et al., 2012) and our ChIP data demonstrate Bul2/Rsp5 recruitment at stalled replication forks. Thus, cohesin could undergo ubiquitylation by Bul2/Rsp5 upon localization of the ligase to stalled forks via its interaction with Mec1/Ddc2.

The functional meaning of the interaction between Bul2/Rsp5 and Mec1/Ddc2 complexes remains intriguing. We do not have evidence of interplay between Mec1/Ddc2 and Bul2/Rsp5 that may involve reciprocal post-translational modification: it seems that Ddc2/Mec1 is not ubiquitylated in a Bul2/Rsp5-dependent manner, nor Bul2 or Rsp5 are phosphorylated in a checkpoint-dependent manner. These

negative results do not exclude an influence of the Mec1-dependent checkpoint response on Bul2/Rsp5 function. Of note, recent data from the laboratory demonstrate that ubiquitylation of cohesin subunits is dependent on Mec1. A simple regulatory mechanism might imply that Mec1/Ddc2 is responsible for directing Bul2/Rsp5 ubiquitylation activity to stalled replication forks (Fig 4.1)

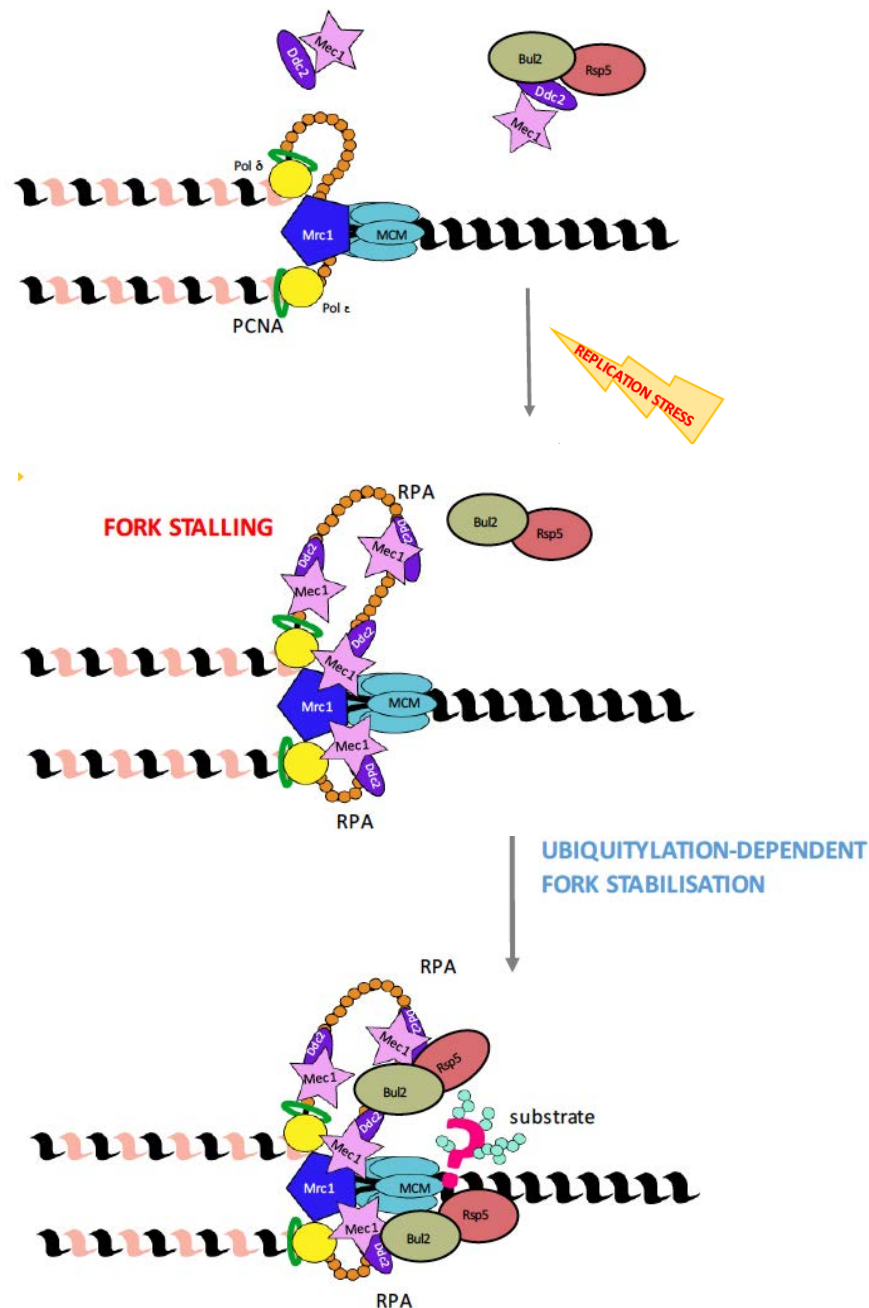

**Figure 4.1. Mec1/Ddc2 drive Bul2/Rsp5 activity to stalled replication forks.** Inhibition of DNA synthesis causes fork stalling leading to the accumulation of long stretches of ssDNA coated by RPA (orange). The apical kinase complex formed by Mec1 (pink) and Ddc2 (purple) is then

recruited at stalled replication forks via Ddc2 interaction with RPA-coated ssDNA. The Bul2/Rsp5 ubiquitin ligase associates to Mec1/Ddc2 and is driven to stalled replication forks where it promotes ubiquitylation events necessary for replication fork re-start.

We found that *bul2* and *rsp5* mutants are also sensitive to MMS, suggesting that re-start promoting function mediated by Bul2/Rsp5 could participate in a general mechanism responding to different types of replication stress. In fact, we demonstrated that Bul2/Rsp5 function is genetically related to that of the cohesin complex, that has been recently involved in facilitating fork re-start upon MMS treatment (Tittel-Elmer et al., 2012). It would be interesting to analyse the contribution of Bul2/Rsp5 and cohesin to the stabilization of replication forks stalled at natural pausing sites in the genome such as hard to replication sequences, tRNAs, centromeres, sites of conflict with transcription (McGlynn et al., 2012; Prado & Aguilera, 2005) or replication forks barriers on rDNA (Kobayashi & Kobayashi, 2003; Mohanty & Bastia, 2004).

The characteristic ring structure of the cohesin complex led to the proposal that it binds to DNA by topological embrace (Haering et al., 2008). Topological entrapment is thought to be crucial for cohesin complex function and an intact ring structure is required to maintain sister chromatid cohesion. Because of its function in tethering sister duplexes, cohesin is essential during mitosis for accurate chromosome segregation (Blow & Tanaka, 2005) and in mammalian cells it is proposed to act as an intramolecular linker regulating insulator-enhancer-promoter interactions, leading to both enhancement and inhibition of genes transcription (Wendt et al., 2008). In line with this model, human cohesin has been involved in the formation of chromatin loops at DNA replication factories that may provide a favourable environment to processes such as DNA replication, transcription and repair (Guillou et al., 2010). This ability of holding sister chromatids together is also exploited by cohesin during DSB (DSB) repair. Cohesin is required for post-replicative repair of double-strand breaks (DSBs) via homologous recombination (HR) (Cortés-Ledesma & Aguilera, 2006; González-Barrera et al., 2003; Ünal et al., 2007). HR processes are genetic recombination events in which nucleotide sequences are exchanged between two identical molecules of DNA. We can

hypothesise that cohesin function upon treatment with MMS, which causes DNA alkylation, could favour a recombination-mediated replication re-start event to by-pass the lesion and resume replication (Branzei & Foiani, 2005). In this view cohesin could facilitate DNA synthesis resumption by maintaining sister chromatids in a conformation that favours recombination-dependent fork re-start. However, it is still unclear whether template switch events assist fork stability or re-start upon stalling caused by depletion of dNTP pools. Alternatively, cohesion may assist fork re-start by promoting a stable replisome-fork DNA architecture. Cohesin function in sister chromatid cohesion is intimately related to replication fork progression. First, establishment of cohesion is elegantly coupled to DNA replication, by the acetylation of the Smc3 in S-phase by the fork associated Eco1 acetyltransferase (Rowland et al., 2009; Skibbens, 2009). In this way sister chromatid replication and their topological entrapment by cohesion is spatially and temporally coupled.

Furthermore, there is an intriguing interplay between proteins involved in replisome structure and stability and sister chromatid cohesion establishment during DNA replication. Factors contributing to the dynamic architecture of the replisome such as Mrc1, Ctf4 and the fork protection complex (FPC) factors Tof1 and Csm3 (Mayer et al., 2004) are required to properly establish sister chromatid cohesion (Noguchi et al., 2004; Sommariva et al., 2005). The mechanisms determining this interconnection are obscure. FPC is thought to coordinate leading and lagging strand DNA synthesis at replication forks (Leman & Noguchi, 2012). Lagging strand processing has been linked with Smc3 acetylation: Eco1 interaction with Fen1, the endonuclease required for Okazaki fragment maturation, is probably required to position the acetyltransferase to act on Smc3 as the replisome passes through or displaces the cohesin ring (Liu et al., 2004; Rudra & Skibbens, 2012). Ctf18 and Ctf4 which are part of the RFC complex are also required for proper sister chromatid cohesion possibly by a polymerase switching event that involves the displacement of polymerase  $\alpha$  to the processive polymerases (Hanna et al., 2001). Therefore a reciprocal crosstalk seems to exist in which replisome stabilising factors are required for cohesion establishment and cohesin is important for fork re-start, perhaps by promoting replisome stability. We hypothesise that the structural challenges faced by forks stalled due to dNTPs depletion (i.e. accumulation

of excessive ssDNA and uncoupling between leading and lagging strand synthesis and DNA unwinding) might impose the necessity for an additional layer of cohesin regulation permitting a non-deleterious stalled replisome-cohesin interfacing. Thus, structural stabilization of sister chromatids in the context of a challenged replisome could be the essential function played by cohesin in promoting fork re-start. This function of cohesin is consistent with synthetic gene array (SGA) analysis indicating that cohesin mutants show negative genetic interactions with genes involved in fork stabilization, but not with genes involved in DSB repair (McLellan et al., 2012).

A SUMO-dependent step during establishment of sister chromatid cohesion has been recently reported (Almedawar et al., 2012). This event occurs after cohesin loading and independently from Eco1-mediated cohesin acetylation. Almedawar et al. proposed that sumoylation might promote sister chromatid cohesion through mechanisms that involve transient opening of the ring during the process of cohesion establishment at replication forks. The short-lived nature of SUMO is consistent with a transient modification of cohesin necessary to promote entrapment of the two sister chromatids. Ubiquitylation of cohesin may exert a similar function. Rsp5-mediated ubiquitin chains have been involved in substrate relocalisation rather than degradation by the proteasome (Crapeau et al., 2014). We propose that Bul2/Rsp5-dependent ubiquitylation is a non-proteolytic signal mediating cohesin mobilization and facilitates dynamic interfacing with the replisome in response to replication stress. The connections with acetylation-dependent cohesion establishment would be an interesting aspect to be analysed in future research.

But how can ubiquitylation of cohesin by Bul2/Rsp5 stimulate replication fork re-start? To try to answer this question we should consider a new intriguing player in the complicate game of ubiquitylation: Cdc48. The ring-like AAA+ ATPase Cdc48/p97 emerges as a key regulator of protein complexes that are marked by ubiquitin or SUMO. Mechanistically, Cdc48 functions as a segregase facilitating the extraction of target proteins from chromatin or other subcellular components. The cellular processes that rely on Cdc48 segregase activity are diverse, ranging from degradation of damaged proteins associated with endoplasmic reticulum (Braun et al., 2002;

Jarosch et al., 2002; Rabinovich et al., 2002) or mitochondria (Fang et al., 2015; Hemion et al., 2014), ribosome-associated quality control (Brandman et al., 2012; Ossareh-Nazari et al., 2010; Verma et al., 2013) and lysosomal proteolysis (Buchan et al., 2013; Ritz et al., 2011; Tresse et al., 2010). Recently, great attention has been paid to the role of Cdc48 in the direct modulation of chromatin-associated protein complexes (Dantuma & Luijsterburg, 2014). It has become evident that Cdc48 not only participates in processing DSBs by modulating the recruitment of repair factors (Balakirev et al., 2015; Centore et al., 2012; Meerang et al., 2011; Nie et al., 2012), but it is also involved in unperturbed DNA replication (Franz et al., 2016; Mouysset et al., 2008). In *C. elegans* it has been reported that the abundance of the licensing factor CDT-1 on chromatin relies on CDC48/p97 activity during initiation of DNA replication (Franz et al., 2012). In yeast cells and *Xenopus* egg extracts Cdc48 is responsible for the release of the MCM helicase at sites of replication termination (Maric et al., 2014; Priego Moreno et al., 2014). In yeast, the ligase complex SCF<sup>Dia2</sup> catalyzes the ubiquitylation of Mcm7 and thus provide the signal for CMG disassembly by Cdc48 (Maculins et al., 2015; Maric et al., 2014). Interestingly, Cdc48 has been recently related to Rsp5 function. Rsp5-mediated Lys-63 polyubiquitin chains on Rpb1 are trimmed down by the DUB Ubp2, resulting in mono-ubiquitylated RNAP II (Harreman et al., 2009). Lys48-linked ubiquitin chains are then built from mono-ubiquitylated RNAP II by an Elongin/Cullin 3 complex, thus promoting RNAP II degradation after its extraction from chromatin with the Cdc48 segregase (Harreman et al., 2009; Verma et al., 2011; Wilson et al., 2013). Consistently to a role of Cdc48 in replication stress, it has been recently proposed that RPA ubiquitylation upon replication stress is occurring on chromatin and would be the signal for its removal from DNA by a Cdc48/p97-mediated process (Elia et al., 2015). Noteworthy, we found Cdc48 among the physical interactors of Bul2 by MS analysis, and genetic data from the laboratory indicate epistasis between Bul2/Rsp5-cohesin and Cdc48 in promoting the survival to replication stress. It is therefore reasonable to think that cohesin ubiquitylation by Bul2/Rsp5 may contribute to its Cdc48-dependent mobilization in response to replication stress. It would be interesting to identify the nature of Bul2/Rsp5-dependent ubiquitin chains and if cohesin distribution around stalled replication forks change in the absence of a functional Cdc48.

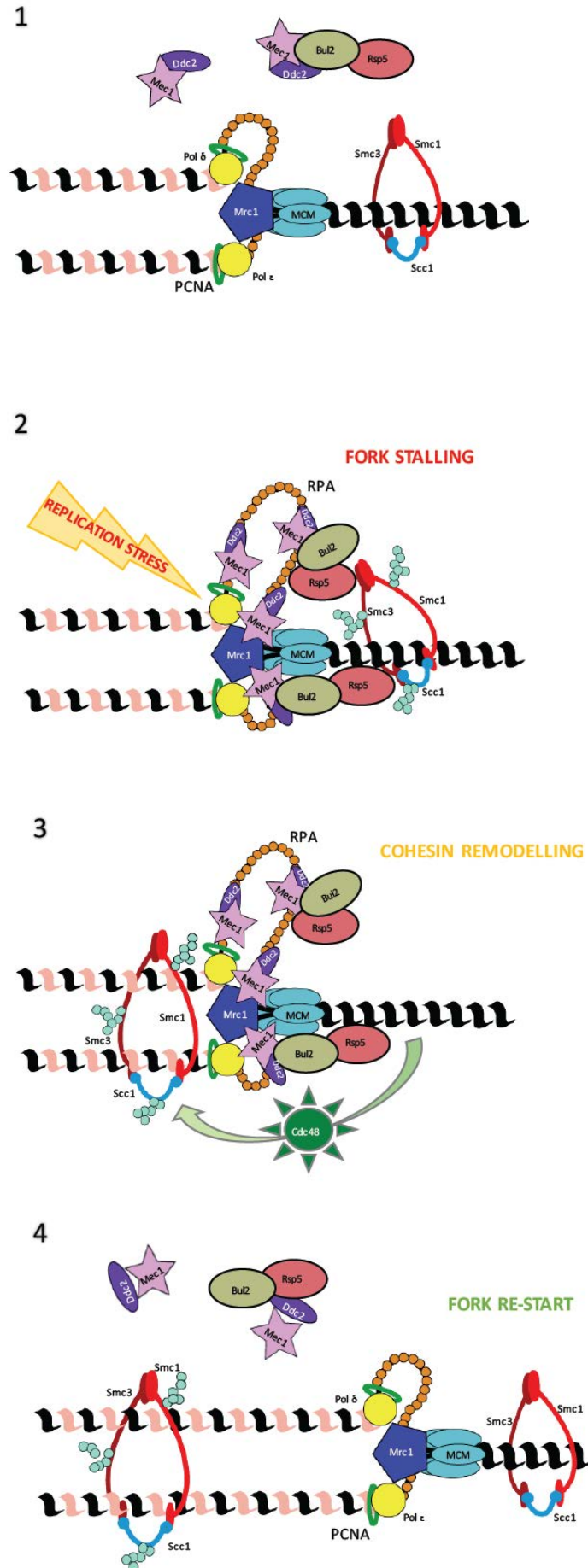

**Figure 4.2. Bul2/Rsp5 ubiquitin ligase complex promotes cohesin-mediated fork re-start.** (1) Unperturbed replication forks interface with cohesin loaded to the parental duplex. (2) Upon inhibition of DNA synthesis by dNTP pools depletion, Mec1 (pink) and Ddc2 (purple) are recruited to structurally altered stalled replication forks. Mec1/Ddc2 interaction with Bul2/Rsp5 (green/red) recruits the ligase complex to the vicinity of replication forks where it promotes the ubiquitylation of the Smc1, Smc3 and Scc1 cohesin subunits. (3) Cohesin ubiquitylation favours its mobilisation from chromatin by the Cbc48 segregase (dark green), which may assist its positioning behind the stalled fork and the entrapment of sister chromatids. (4) Relocated cohesin preserves the structural integrity of fork DNA-replisome architecture, thus promoting the resumption of DNA synthesis and stable fork re-start once dNTP levels are recovered.

Even if more work has to be done to elucidate the molecular mechanisms involved, we propose that Bul2/Rsp5 promotes replication fork re-start through remodelling of cohesin (Fig 4.2). Cells suffering replication stress activate the checkpoint signalling cascade to stabilise replication forks and preserve genome integrity. Mec1/Ddc2 complex is recruited at stalled replication forks by its interaction with ssDNA and drives Bul2/Rsp5-dependent poly-ubiquitylation of fork-associated cohesin. These ubiquitylation events might favour cohesin mobilization ahead the replisome via Cdc48. We speculate that once extracted ahead of replication forks, cohesin may be more efficiently placed behind stalled forks where it would contribute to maintain the replication fork architecture in a conformation that favours stable replisome-fork DNA architecture or HR-dependent fork re-start.



## 5. Conclusion

The data presented in this work lead to the following conclusions:

- 1) The Rsp5 HECT-domain ubiquitin ligase is assisted by its adaptor Bul2 to promote cell viability in response to replication stress.
- 2) Bul2/Rsp5-mediated ubiquitylation events are required for the re-start of replication forks experiencing replication stress and their stable progression throughout the genome.
- 3) Bul2/Rsp5 physically interacts with Mec1/Ddc2 checkpoint activator complex, likely directing the ubiquitin ligase activity to stalled replication forks.
- 4) Bul2/Rsp5 complex physically interacts with cohesin during replication stress, a function presumably related to cohesin ubiquitylation in cells experiencing replication stress.
- 5) Cohesin mediates the re-start of replication forks stalled by DNA synthesis inhibition upon dNTP pool depletion.
- 6) Bul2/Rsp5-dependent ubiquitylation stimulates cohesin-mediated replication fork re-start, in a mechanism probably involving cohesin remodelling at forks.



## 6. Materials and Methods

### 6.1 Strains and plasmids.

All W303 strains used in this study are isogenic derivatives of **W303-1a** *RAD5* background (Thomas & Rothstein, 1989). The genotype is listed in the table below (Table 6.1). Plasmid used by specific strategies are listed in Table 6.2. Deletion strains were constructed using PCR-based gene disruption strategy (Brachmann et al., 1998; Longtine et al., 1998). Protein tagging was performed by introducing the in-frame sequence of the corresponding epitope (FLAG, HA, MYC, PK) at the C-terminal end of the gene of interest.

**Table 6.1: Genotype of strains generated and used in this study**

| STRAIN                | NUMBER | GENOTYPE   | REFERENCE      |
|-----------------------|--------|--|----------------|
| WT                    | RB718  | <i>MATa, ADE2, can1-100, his3-11,15 leu2-3,112 trp1-1, ura3-1</i>  | lab collection |
| <i>rsp5-25 sup4-o</i> | RB389  | <i>MATa, ADE2, can1-100, his3-11,15 leu2-3,112 trp1-1 ura3-1, RSP5::rsp5-25, SUP4o::CAN1-HIS3::sup4</i>  | this study     |
| Ddc2-Myc ev           | RB589  | <i>MATa, ADE2, can1-100, his3-11,15 leu2-3,112 trp1-1, ura3-1, DDC2-Myc-TRP-, YEplac195</i>              | this study     |
| Ddc2-Myc Ub           | RB590  | <i>MATa, ADE2, can1-100, his3-11,15 leu2-3,112 trp1-1, ura3-1, DDC2-Myc-TRP1, YEplac195CUP1-HIS7-Ubi</i> | this study     |
| <i>sup4-o</i>         | RB964  | <i>MATa, ADE2, can1-100, his3-11,15 leu2-3,112 trp1-1 ura3-1, SUP4o::CAN1-HIS3::sup4</i>                 | this study     |

The Bul2/Rsp5 ubiquitin ligase complex promotes cohesin-mediated for re-start

|  |        |  |            |
|--|--------|--|------------|
| <i>smc3-42</i>   | RB997  | <i>MATa, ADE2, can1-100, his3-11,15 leu2-3,112 trp1-1, ura3-1, GAL psi+, smc3-42</i>   | this study |
| <i>bul2Δ</i>   | RB1070 | <i>MATa, ADE2, can1-100, his3-11,15 leu2-3,112 trp1-1, ura3-1, bul2::His3MX6</i>   | this study |
| Bul2-PK<br>Ddc2-Myc<br>HA-Rsp5                                 | RB1090 | <i>MATa, ADE2, can1-100, his3-11,15 leu2-3,112 trp1-1, ura3-1, BUL2-9PK::KanMX6, DDC2-Myc-TRP1, HA-RSP5</i>                                  | this study |
| <i>bul1Δ</i>   | RB1142 | <i>MATa, ADE2, can1-100, his3-11,15 leu2-3,112 trp1-1, ura3-1, bul1::NatMX4</i>  | this study |
| <i>bul1Δ bul2Δ</i>   | RB1207 | <i>MATa, ADE2, can1-100, his3-11,15 leu2-3,112 trp1-1, ura3-1, bul1::NatMX4, bul2::His3MX6</i>   | this study |
| Bul2-Flag<br>Smc3-PK<br>HA-Rsp5                                | RB1219 | <i>MATa, ADE2, can1-100, his3-11,15 leu2-3,112 trp1-1, ura3-1, BUL2::BUL2-10Flag-KAN, HA-RSP5, SMC3::SMC3-9PK-KAN</i>                        | this study |
| Bul2-Flag<br>Smc1-PK<br>HA-Rsp5                                | RB1228 | <i>MATa, ADE2, can1-100, his3-11,15 leu2-3,112 trp1-1, ura3-1, BUL2::BUL2-10Flag-KAN, HA-RSP5, SMC1::SMC1-9PK-KAN</i>                        | this study |
| <i>rsp5-1</i>  | RB1263 | <i>MATa, ADE2, can1-100, his3-11,15 leu2-3,112 trp1-1, ura3-1, RSP5::rsp5-1</i>  | this study |
| Bul2-PK <i>sml1Δ</i><br><i>mec1Δ tel1Δ</i>                     | RB1474 | <i>MATa, ADE2, can1-100, his3-11,15 leu2-3,112 trp1-1, ura3-1, BUL2::BUL2-9PK-KanMX6, sml1::TRP1, mec1::URA3, tel1::HPH</i>                  | this study |
| Bul2-PK <i>sml1Δ</i>   | RB1486 | <i>MATa, ADE2, can1-100, his3-11,15 leu2-3,112 trp1-1, ura3-1, BUL2::BUL2-9PK-KanMX6, sml1::TRP1</i>   | this study |
| HA-Rsp5 <i>sml1Δ</i><br><i>mec1Δ tel1Δ</i>                     | RB1498 | <i>MATa, ADE2, can1-100, his3-11,15 leu2-3,112 trp1-1, ura3-1, HA-RSP5, sml1::TRP1, mec1::URA3, tel1::HPH,</i>                               | this study |
| HA-Rsp5 <i>sml1Δ</i>   | RB1510 | <i>MATa, ADE2, can1-100, his3-11,15 leu2-3,112 trp1-1, ura3-1, HA-RSP5, sml1::TRP1</i>   | this study |
| Bul2-PK<br>Ddc2-Myc<br>HA-Rsp5 <i>sml1Δ</i><br><i>mec1-kd1</i> | RB1522 | <i>MATa, ADE2, can1-100, his3-11,15 leu2-3,112 trp1-1, ura3-1, BUL2::BUL2-9PK-KanMX6, DDC2::DDC2-Myc-TRP1, HA-RSP5, sml1::TRP1, mec1-kd1</i> | this study |

|  |        |   |                 |
|--|--------|---|-----------------|
| Bul2-PK<br>Ddc2-Myc<br>HA-Rsp5 <i>sm1Δ</i> | RB1546 | <i>MATa, ADE2, can1-100, his3-11,15 leu2-3,112 trp1-1, ura3-1, BUL2::BUL2-9PK-KanMX6, DDC2::DDC2-Myc-TRP1, HA-RSP5, sm1::TRP1</i> | this study      |
| <i>bul1Δ bul2Δ smc3-42</i>                 | RB1680 | <i>MATa, ADE2, can1-100, his3-11,15 leu2-3,112 trp1-1, ura3-1, GAL psi+, smc3-42, bul2::HIS3 bul1::NatMX4</i>                     | this study      |
| <i>bul1Δ bul2Δ SCE</i>                     | RB1857 | <i>MATa, can1-100, his3-11,15 leu2-3,112 trp1-1, ura3-1, bul1::NatMX4, bul2::HIS3, ade2-nde::TRP1::ade2-lscel+/aat</i>            | this study      |
| WT SCE                                     | RB1889 | <i>MATa, can1-100, his3-11,15 leu2-3,112 trp1-1, ura3-1, ade2-nde::TRP1::ade2-lscel+/aat</i>                                      | Symington's lab |
| Ddc2-Myc<br><i>rsp5-25 ev</i>              | RB2033 | <i>MATa, ADE2, can1-100, his3-11,15 leu2-3,112 trp1-1, ura3-1, DDC2-Myc-TRP1, YEplac195</i>                                       | this study      |

**Table 6.2: Plasmids used in this study**

| PLASMID                        | NUMBER | AIM   | REFERENCE                     |
|--------------------------------|--------|---|-------------------------------|
| <i>pLS189</i>                  | BB37   | Sister Chromatid Exchange ( <i>ade2-n::TRP1::ade2-1</i> ) | Lab collection (L. Symington) |
| <i>YEplac195</i>               | BB7    | Empty vector Pull Down ( <b>ev</b> )                      | Lab collection (H. Ulrich)    |
| <i>YEplac195-CUP1-HIS7-Ubi</i> | BB8    | Ubi vector Pull Down ( <b>Ubi</b> )                       | Lab collection (H. Ulrich)    |

## 6.2 Growing media for *Saccharomyces cerevisiae* cells.

### Solid media:

- Complete media YPD:

|                              |        |
|------------------------------|--------|
| Yeast extract                | 4 g    |
| Peptone                      | 8 g    |
| Agar                         | 8 g    |
| D-glucose 40%                | 20 mL  |
| H <sub>2</sub> O (milli Rho) | 380 mL |
  
- Complete media YPDA:

|                              |        |
|------------------------------|--------|
| Yeast extract                | 4 g    |
| Peptone                      | 8 g    |
| D-glucose 40%                | 20 mL  |
| Agar                         | 8 g    |
| H <sub>2</sub> O (milli Rho) | 380 mL |

Insoluble adenine was added at a final concentration of 25 µg/mL.

- Synthetic complete (SC):

|                              |                         |
|------------------------------|-------------------------|
| YNB (w/o aa)                 | 2.8 g                   |
| Agar                         | 8 g                     |
| D-glucose 40%                | 20 mL                   |
| H <sub>2</sub> O (milli Rho) | 380 mL                  |
| <b>Drop-out (+/- Ade)*</b>   | 16 mL                   |
| HIS, TRP, LEU, URA           | C <sub>f</sub> 25 µg/mL |

This medium was only used to measure sister chromatids recombination. Plates without Adenine were used to select for recombinants as it will be explained later in this chapter.

- Minimum media:

|                              |        |
|------------------------------|--------|
| YNB (w/o aa)                 | 2.8 g  |
| Agar                         | 8 g    |
| D-glucose 40%                | 20 mL  |
| H <sub>2</sub> O (milli Rho) | 380 mL |
| <b>Drop-out*</b>             | 16 mL  |

Aminoacids used for selection (HIS, TRP, LEU, URA) were added at the final concentration ( $C_f$ ) of 25  $\mu\text{g}/\text{mL}$

|  |  |         |
|--|--|---------|
| <b>*DROP-OUT</b> (final volume 2 L):       |  |         |
| Thr  |  | 1.2 g   |
| Phe  |  | 1.2 g   |
| Ile  |  | 1.2 g   |
| Lys  |  | 1.2 g   |
| Arg  |  | 1.2 g   |
| Tyr  |  | 1.2 g   |
| Ino  |  | 1.74 g  |
| Ade  |  | 1.2 g   |
| Etoh 100%                                  |  | 120 mL  |
| ddH <sub>2</sub> O                         |  | 1800 mL |
| • YNB (Yeast Nitrogen Base):               |  |         |
| YNB (w/o aa)                               |  | 2.8 g   |
| Agar                                       |  | 8 g     |
| D-glucose 40%                              |  | 20 mL   |
| H <sub>2</sub> O (milli Rho)               |  | 380 mL  |
| • Sporulation medium (VB):                 |  |         |
| Anhydro CH <sub>3</sub> CO <sub>2</sub> Na |  | 3.28 g  |
| KCl  |  | 0.76 g  |
| NaCl                                       |  | 0.48 g  |
| MgSO <sub>4</sub>                          |  | 0.14 g  |
| Agar                                       |  | 6 g     |
| H <sub>2</sub> O (milli Rho)               |  | 400mL   |



**Buffer G2** (digestion buffer): 800mM guanidine HCl, 30mM Tris-HCl pH 8.0, 30mM EDTA pH 8.0, 0.5% Tween-20, 0.5% Triton X-100

**Buffer QBT** (equilibration buffer): 750mM NaCl, 50mM MOPS pH 7.0, 15% Isopropanol, 0.15% Triton X-100

**Buffer QC** (wash buffer): 1M NaCl, 50mM MOPS pH 7.0, 15% Isopropanol

**Buffer QF** (elution buffer): 1.25M NaCl, 50mM Tris-HCl pH 8.5, 15% Isopropanol

**Denaturing solution:** 0.5M NaOH, 1.5M NaCl

**Elution Buffer:** 50mM Tris-HCl pH 8.0, 10mM EDTA, 1% SDS

**FACS Buffer solution:** 200mM Tris-HCl pH 7.4, 200mM NaCl, 80mM MgCl<sub>2</sub>

**Laemmli Buffer 1X:** 2% SDS, 10% Glycerol, 5% β-mercaptoethanol, 0.002% Bromophenol blue, 0.125 M Tris-HCl pH 6.8

**Lysis Buffer:** 50mM Hepes-KOH pH 7.5, 140mM NaCl, 1mM EDTA, 1% Triton X-100, 0.1% Na-deoxycholate

**NIB Buffer (pH 7.2):** 17% Glycerol, 50mM MOPS, 150mM K-acetate, 2mM MgCl<sub>2</sub>, 500mM Spermidine, 150mM Spermine

**One-Phor-All-Buffer 10X:** 100mM Tris-Acetate pH 7.5, 100mM Mg-Acetate, 500mM K-Acetate

**PBS:** 137mM NaCl, 10mM PO<sub>4</sub>, 2.7mM KCl

**Ponceau S:** 0.1% Ponceau S, 1% acetic acid, H<sub>2</sub>O

**SSC 20X:** 3M NaCl, 0.3M Na citrate (C<sub>6</sub>H<sub>5</sub>Na<sub>3</sub>O<sub>7</sub>)

**Red Mix Buffer:** contains all the necessary reagents required for PCR (Taq HS polymerase and dNTPs), it only requires the addition of template, primers and water

**Running Buffer 1X:** 25mM Tris-base, 192mM Glycine, 0.1% SDS

**SSR 2X:** 0.25M Tris-HCl pH 6.8, 4% SDS, 10% sucrose, 0.025% Bromophenol blue, 1% β-mercaptoethanol

**TAE:** 0.04M Tris-Acetate, 0.001M EDTA

**TBE:** 89mM Tris-Borodate, 89mM Boric Acid, 2mM EDTA

**TBS:** 20mM Tris-HCl pH 7.5, 150mM NaCl

**TE:** 10mM Tris-HCl pH 7.4, 1mM EDTA

**TE1X-SDS 1%:** 10mM Tris-HCl pH 8.0, 1mM EDTA, 1% SDS

**Transfer Buffer:** Glycine 1%, Tris-base 0.02M, Methanol 20%

**Wash Buffer:** 10mM Tris-HCl pH8.0, 250mM LiCl, 0.5% NP-40, 0.5% Na-deoxycholate, 1mM EDTA

**Washing solution I:** SSC 2X, 1% SDS

**Washing solution II:** SSC 0.1X, 0.1% SDS

## **6.4 PCR.**

The Polymerase Chain Reaction is used for the in vitro amplification of specific DNA sequences to transform yeast cells and produce yeast mutants. The PCR reaction requires two oligonucleotide sequences (17-30 base pairs) flanking the DNA region to amplify (primers). PCR reaction is divided into three steps, each of them with a specific temperature. The cycle of denaturing-annealing-extension is repeated 20-30 times to have a satisfactory amplification of the desired sequence.

- **denaturing:** the double helix is separated into the two single helices by heating (T = 94°C).
- **annealing:** at a lower temperature each primer recognizes and binds to its complementary sequence in one of the two separated helices (T = 45-60°C). The primers have a free 3'-end in order to make possible the synthesis on both DNA strands.
- **extension:** starting from the primers the DNA polymerase synthesizes in a 5'-3' direction new DNA helix using the four dNTPs added to the reaction (T = 72°C).

Different PCR reaction mixtures and programmes were used according to the specific DNA sequence (cassette) to amplify:

- **DELETION (HIS, TRP, URA) or TAG (MYC) cassette**

|  |              |      |       |            |
|--|--------------|------|-------|------------|
| Buffer 10X (Biotools 10.002)           | 100 $\mu$ L  | 94°C | 3'    |            |
| dNTPs (2mM)                            | 100 $\mu$ L  | 94°C | 30"   | } 8 cycles |
| primer forward (250 ng/ $\mu$ L)       | 20 $\mu$ L   | 42°C | 30"   |            |
| primer reverse (250 ng/ $\mu$ L)       | 20 $\mu$ L   | 72°C | 1'30" |            |
| specific DNA template (20 ng/ $\mu$ L) | 10 $\mu$ L   | 94°C | 30"   |            |
| Dynazyme polymerase                    | 20 $\mu$ L   | 58°C | 30"   |            |
| ddH <sub>2</sub> O sterile             | 730 $\mu$ L  | 72°C | 1'30" |            |
|  |              | 72°C | 7'    |            |
| final volume                           | 1000 $\mu$ L |      |       |            |

- **FLAG TAG cassette**

|                                  |              |       |       |             |
|----------------------------------|--------------|-------|-------|-------------|
| Buffer 10X (Biotools 10.002)     | 100 $\mu$ L  | 94°C  | 3'    |             |
| dNTPs (2mM)                      | 100 $\mu$ L  | 94°C  | 1'    | } 32 cycles |
| primer forward (250 ng/ $\mu$ L) | 10 $\mu$ L   | 42°C  | 1'    |             |
| primer reverse (250 ng/ $\mu$ L) | 10 $\mu$ L   | 72°C  | 1'30" |             |
| BB7 (10 ng/ $\mu$ L)             | 20 $\mu$ L   | 94°C  | 10'   |             |
| Dynazyme polymerase              | 20 $\mu$ L   |       |       |             |
| ddH <sub>2</sub> O sterile       | 730 $\mu$ L  |       |       |             |
|                                  |              | ----- |       |             |
| final volume                     | 1000 $\mu$ L |       |       |             |

• **PK-TAG cassette**

|                              |         |      |      |             |
|------------------------------|---------|------|------|-------------|
| Buffer 10X (Biotools 10.002) | 100 µL  | 94°C | 5'   |             |
| dNTPs (2mM)                  | 100 µL  | 94°C | 15'' | } 32 cycles |
| primer forward (250 ng/µL)   | 10 µL   | 45°C | 15'' |             |
| primer reverse (250 ng/µL)   | 10 µL   | 72°C | 2'   |             |
| BB6 (10 ng/µL)               | 20 µL   | 72°C | 7'   |             |
| Dynazyme polymerase          | 20 µL   |      |      |             |
| ddH <sub>2</sub> O sterile   | 730 µL  |      |      |             |
| -----                        |         |      |      |             |
| final volume                 | 1000 µL |      |      |             |

• **CLONAT (NAT) and HYGROMYCIN (HPH) DELETION cassette**

|                              |         |      |      |             |
|------------------------------|---------|------|------|-------------|
| iProof GC Buffer 5X (BIORAD) | 200 µL  | 98°C | 2'   |             |
| dNTPs (2mM)                  | 100 µL  | 98°C | 15'' | } 5 cycles  |
| primer forward (250 ng/µL)   | 20 µL   | 49°C | 20'' |             |
| primer reverse (250 ng/µL)   | 20 µL   | 72°C | 40'' |             |
| BB19/BB70 (10 ng/µL)         | 10 µL   | 98°C | 15'' |             |
| Phusion polymerase           | 10 µL   | 65°C | 20'' | } 35 cycles |
| ddH <sub>2</sub> O sterile   | 640 µL  | 72°C | 40'' |             |
|                              |         | 72°C | 5'   |             |
| -----                        |         |      |      |             |
| final volume                 | 1000 µL |      |      |             |

PCR products were analysed on a 0,8% agarose/TAE 1X gel and precipitated by the addition of 1/10 volume of 3M Sodium Acetate (CH<sub>3</sub>CO<sub>2</sub>Na) and 2.5 volume of cold 100% EtOH and a 10 minutes centrifugation at maximum speed at 4°C. Pellets were washed with 1 ml of cold 70% EtOH and re-centrifuged (2 minutes, maximum speed, 4°C), dried and re-suspended in sterile TE 1X to reach a final concentration of 1 µg/µl DNA. Different DNA quantities from this stock solution were then used for transformation.

Plasmids used to amplify PCR cassette are listed in the table below:

**Table 6.3: Plasmids used for PCR**

| PLASMID NAME            | NUMBER | REFERENCE      |
|-------------------------|--------|----------------|
| <i>pPK9-KanMX6</i>      | BB6    | Lab collection |
| <i>pU6H3FLAG</i>        | BB7    | Lab collection |
| <i>pFA6a-His3MX6</i>    | BB8    | Lab collection |
| <i>pFA6a-TRP1</i>       | BB9    | Lab collection |
| <i>pFA6a-13Myc-TRP1</i> | BB14   | Lab collection |
| <i>p4339 (NAT)</i>      | BB19   | Lab collection |
| <i>pRS406 (URA3)</i>    | BB47   | Lab collection |
| <i>pAG32 (HPH)</i>      | BB70   | Lab collection |

### 6.5 High efficiency LiAC transformation.

To generate knock out mutants or strains that express a tag version of the protein of interest we used a high efficiency transformation protocol. Strains to be transformed were grown in a pre-culture of 5 mL of YPDA in a 50 mL falcon tube. Cells were then counted at the microscope, diluted in 50 mL of YPD and let grow over night to reach the day after the final concentration of  $5 \times 10^6$  cell/mL. The following day, the culture were centrifuged for 3 minutes at 4000 rpm and the pellet was rinsed with 25 mL of sterile water to wash away completely the medium. The pellet obtained after a second centrifugation was resuspended in 1 mL di 0.1M LiAc/TE 1X and transferred in a 1,5 mL Eppendorf tube. Cells were centrifuged at maximum speed for 15 seconds and resuspended in a final volume of 500  $\mu$ L di 0.1M LiAc/TE 1X. The cell suspension is vortexed and split into individual 50  $\mu$ L aliquotes for each transformation. Meanwhile salmon sperm DNA (ss-DNA) was boiled 5 minutes at 95°C in order to use it as DNA carrier.

The 50  $\mu$ L cell suspension was centrifuged at maximum speed for 15 seconds and the transformation mix was added to te pellet in the following order:

|                              |                         |
|------------------------------|-------------------------|
| PEG (50% W/v)                | 240 $\mu$ L             |
| 1M LiAc                      | 36 $\mu$ L              |
| ss-DNA (9.5 mg/mL)           | 10.5 $\mu$ L            |
| DNA (plasmid or PCR product) | 1-5 $\mu$ g (x $\mu$ L) |
| sterile ddH <sub>2</sub> O   | 73.5 - x $\mu$ L        |
|                              | -----                   |
| final volume                 | 360 $\mu$ L             |

For cell transformation different amounts (1-5  $\mu$ g) of DNA were used and the corresponding  $\mu$ L of ddH<sub>2</sub>O were added to reach the final volume of 360  $\mu$ L. The transformation mix was vortexed vigorously for at least 1 minute to obtain a homogenous mixture that was incubated 40 minutes at 42°C: in this step, called “heat shock”, cells incorporate the DNA contained in the mix.

After the heat shock, cells were centrifuged for 15 seconds at 7000 rpm, the transformation mix was removed with the vacuum pump and the pellet was resuspended in a small volume of sterile water to be easily plated in the corresponding selective medium. If the cassette used to transform carried an antibiotic resistance marker, for example naturomycin (NAT) or kanamycin (KAN), cells were let grow for at least 3 hours in 3 mL YPDA before plating to allow them express the resistance gene. Deletion transformants were then selected and analyzed by Colony PCR; protein extraction with subsequent SDS page electrophoresis and WB analysis was performed to check for protein tags.

## **6.6 Colony PCR.**

This technique was used to verify gene deletions. The Polymerase Chain Reaction amplifies the specific nucleotide sequence after cell breakage. A little amount of cells from the colonies of interest was resuspended in 3  $\mu$ L of 20mM NaOH in PCR tubes and boiled at 99° C for 10 minutes.

For the PCR reaction, the following mix was added to 1.5  $\mu$ L of boiled solution:

|   |                         |
|---|-------------------------|
| Red Mix 10X (MyTaq <sup>TM</sup> HS Red Mix)            | 5.5 $\mu$ L             |
| oligo forward (20 $\mu$ M)<br>(gene specific)           | 0.3125 $\mu$ L          |
| oligo reverse (20 $\mu$ M)<br>(gene or marker specific) | 0.3125 $\mu$ L          |
| ddH <sub>2</sub> O sterile                              | 4.875 $\mu$ L           |
| -----   |                         |
| final volume  | 11 $\mu$ L total volume |

General PCR programme:

|      |     |             |
|------|-----|-------------|
| 95°C | 4'  |             |
| 95°C | 15" | } 35 cycles |
| 55°C | 15" |             |
| 72°C | 30" |             |
| 72°C | 5'  |             |

The time and the temperature of the annealing step depended on the size of the fragment to be amplified and the melting temperature of the oligo used in the reaction. The colony PCR products were typically analyzed in a 2% agarose/TAE 1X gel.

### 6.7 Growth conditions, cell cycle arrest and HU treatment.

*S.cerevisiae* strains were grown in rich YPDA media at 30°C, unless differently stated, to a final concentration of  $1 \times 10^7$  cells/mL. Strain with mating type *a* were synchronized in G1 by the addition of synthetic  $\alpha$ -factor pheromone at a final concentration of 5  $\mu$ g/mL. After about 1 hour and 30 minutes in the presence of the pheromone, when more than 90% of cells showed the characteristic *schmoo* shape  $\alpha$ -factor was washed away from the medium by 2 consecutive centrifugations (3 minutes at 3000 rpm). Cells were then resuspended in new YPDA medium or fresh YPDA with the specific HU concentration.

## **6.8 Serial dilutions and spot assay.**

Cells were grown in 110  $\mu$ L of YPDA at 30°C (unless differently stated) on 96-multiwell plates over night to reach stationary phase (plateau). 10 fold serial dilutions are plated on YPDA medium or YPDA containing HU at the indicated concentrations. Plates are incubated at 30°C unless differently stated.

## **6.9 TCA protein extraction.**

10 mL of a  $1 \times 10^7$  cells/mL culture were collected in 15 mL falcon tube, spinned 3 minutes at 4000 rpm, resuspended in 2 mL of 20% TCA (TriChloroacetic Acid), transferred in a 2 mL eppendorf tube and frozen at -20°C or centrifuged 1 minute at maximum speed. The pellet was resuspended in 100  $\mu$ L of 20% TCA and glass beads were added till covering the liquid phase; in order to break cells, the tubes were vortexed 3 minutes at maximum speed and 200  $\mu$ L of 5% TCA were added to the mixture to have 300  $\mu$ L of final 10% TCA. The liquid phase was transferred in a new 1.5 mL eppendorf tube using a 1 mL pipette and, after a 10 minutes centrifugation at 3000 rpm, the pellet was resuspended in 100  $\mu$ L Laemli Buffer 1X plus 50  $\mu$ L of 1M Tris Base to neutralize the acid pH. Samples were resuspended by vortex and boiled at 95°C for 3 minutes, after a 10 minutes centrifugation at 3000 rpm, the supernatant was transferred into a new 1.5 mL eppendorf tube and loaded directly on a SDS-PAGE or conserved at -20°C.

## **6.10 SDS-PAGE and Western Blot analysis.**

This technique consists on protein separation according to their molecular weight. The separation was performed in denaturing conditions on a polyacrilamide matrix with specific percentages of acrylamide and bisacrylamide according to the size of the protein analyzed: the bigger the protein is, the lower percentage of acrylamide/bisacrylamide in the gel was used. Unless differently stated, 10% acrylamide and 0.13% bisacrylamide gels were used. The proteins run in SDS-PAGE Running Buffer through which an electric field was applied and then transferred from the gel to a porous nitrocellulose filter through electric transfer in Transfer

Buffer. The quality of the transfer was checked by Ponceau S staining. The coloured filter was washed with 1% Tween-TBS 1X (T-TBS) and highly reactive protein epitopes were blocked for 1 hour at RT with 4% milk solution in TBS 1X-0.2% TritonX-100. After blocking, the filter was incubated for 2 hours at RT with a milk solution containing the specific primary antibody (EL7 for Rad53, 12CA5 for HA epitope, V5 for PK epitope, FLAG and MYC antibodies for the corresponding tags) at the appropriate dilution. After incubation with the primary antibody, the filter was rinsed and washed twice 10 minutes with T-TBS and incubated for 1 hour at RT with the secondary antibody (anti-mouse-IgG unless differently stated) conjugated to alkaline peroxidase. After incubation with the secondary antibody and 2 washes in T-TBS, the filter was incubated for 1 minute in a substrate solution for the chemoluminescent reaction (Amersham™ ECL™ Western Blotting Detection Reagents by GE Healthcare). The filter was then exposed to photographic films and developed.

- **Phos-tag gels**

Phosphate affinity SDS-PAGE was used to evidence phosphoisoforms of proteins: acrylamide-pendant Phos-tag™ ligand in complex with two manganese(II) ions ( $Mn^{2+}$ -Phos-tag™) provides a high affinity basket for the negative charge of the phosphate of phosphorylated proteins (Fig 6.1), whose run in the gel is delayed. Migration speed of phosphorylated proteins decreases and they are separated from the non-phosphorylated status. For the analysis of the phosphorylation status of Rsp5 and Bul2, Phos-tag™ and  $MnCl_2$  were added directly to the 10% acrylamide running mix to a final concentration of 0.8  $\mu M$  and 3.2  $\mu M$  respectively.

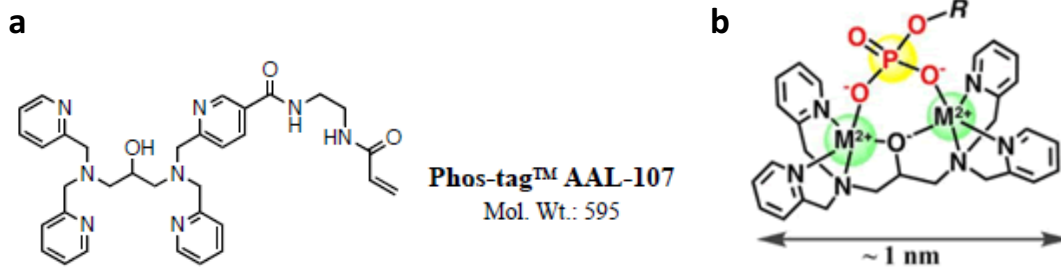

**Figure 6.1. Schematic representation of the acrylamide-pendant Phos-tag ligand and the phosphate-affinity basket. (a)** Phos-tag molecule. **(b)** A stable complex is formed with a phosphate group and the positive basket created by the manganese ions bound to the Phos-tag ligand.

For the analysis of phosphorylated forms of HA-Rsp5 and Bul2-PK individual gels were run at constant 100 volts for 6 hours. Before the transfer of the proteins from the gel to the nitrocellulose membrane the gel was incubated 30 minutes in transfer buffer with 100 mM EDTA pH 8.0, a chelating agent that binds to positive ions, in order to break the binding between the negative charge of the phosphate and the positive one of  $Mn^{2+}$ . After 3 washes of 15 minutes in transfer buffer without EDTA, proteins were transferred from the gel to the nitrocellulose membrane over night (O/N) at 200mA at room temperature (RT).

### 6.11 FACS analysis.

The technique of Fluorescence Activated Cell Sorting (FACS) was used to determine the DNA content of a single cell by analyzing the fluorescence signal of propidium iodide intercalated in the DNA. For this type of analysis, 2 mL of exponentially growing culture ( $1 \times 10^7$  cells/mL) were taken and centrifuged for 1 minute at 13200 rpm. Samples were then resuspended in 1 mL of cold 70% EtOH-250mM Tris-HCl pH 7.6 and left for 1 hour at room temperature. Cells were centrifuged 1 minute at 13200 rpm, resuspended in 450  $\mu$ L of 50mM Tris-HCl pH 7.5 plus 50  $\mu$ L di RNase 10 mg/mL and incubated 1 hour at 37°C. After treatment with RNase, cells were centrifuged and resuspended in 500  $\mu$ L of FACS buffer with 50  $\mu$ L IPr

(propidium iodide 0.5 mg/mL). The propidium iodide is a DNA intercalating agent that when activated by the laser of the cytofluorimeter produces fluorescence in a manner proportional to the DNA content. 200  $\mu$ L of cells treated with IPr were transferred to specific tubes for FACS containing 1 mL of 50mM Tris-HCl pH 7.6. Each sample was sonicated for 15 seconds at 40% of power to separate cells and then read by FACS.

### 6.12 Co-immunoprecipitation assay.

This technique was used to study protein-protein interactions from a whole cell extract.

#### 1<sup>st</sup> day

- *Antibody-bound magnetic beads preparation*

20  $\mu$ L of magnetic beads with protein G (Dynabeads<sup>®</sup> by Life Technologies) were used per 100 mL of culture. The beads were washed twice with 1 mL of PBS 1X/BSA 5mg/mL and resuspended in the appropriate final volume of the same solution (PBS 1X/BSA 5mg/mL). We added 7.5  $\mu$ g of the specific antibody each 20  $\mu$ L of beads and incubated O/N in pre-lubricated Costar tubes on a wheel at 4°C.

- *Cell lysis*

We started with 100 mL of a culture at a concentration of  $1 \times 10^7$  cells/mL. Cells were centrifuged 5 minutes at 5000 rpm and resuspended in 500  $\mu$ L of Lysis Buffer supplemented with 2X Protease Inhibitor (IP) and 10mM PMSF. The resuspension was then split into 4 O-ring tubes and 500  $\mu$ L of glass beads were added. Cells were broken using the fast-prep machine by alternating 5 times 30 seconds of breakage at 4.5 power and 1 minute on ice. After the breakage it was checked that at least 90% of cells was lysed; the supernatant was collected into new 1.5 mL Eppendorf tubes and centrifuged twice 5 minute at maximum speed at 4°C to clarify the cell extracts. Protein concentration of the samples was measured by spectrophotometer at 595 nm. Samples were stored at -80°C or immediately used for immunoprecipitation.

## **2<sup>nd</sup> day**

We used 1 mg of protein for each CoIP in a final volume of 300  $\mu$ L of Lysis Buffer supplemented with IP 2X and 10mM PMSF. Before adding the beads previously washed twice with 1 mL of PBS 1X/BSA 5mg/mL, 3.75  $\mu$ L of extract were taken as WCE (Whole Cell Extract) sample. To the WCE sample we added 6.7  $\mu$ L of Laemly 3X and 9.55  $\mu$ L of H<sub>2</sub>O and the sample was then stored at 4°C until loaded. The extract was incubated from 4 hours to O/N at 4°C on a steering wheel. The time of incubation for the Co-immunoprecipitations performed is 4 hours unless differently noted. After incubation, we took the SUP (SUPernatant) sample (3.75  $\mu$ L of the extract + 6.7  $\mu$ L of Laemly 3X + 9.55  $\mu$ L of H<sub>2</sub>O) and the beads were washed with increasing concentration of salt to reduce the unspecific binding to the antibody: twice with 1 mL of Lysis Buffer, twice with 1 mL of Lysis Buffer supplemented with 72  $\mu$ L/mL 5M NaCl, twice with 1 mL of Wash Buffer and one last wash with 1 mL of TE 1X. All the washes were performed in a magnetic greed and the liquid is taken away with the vacuum pump except for the 1 mL of TE 1X which was eliminated with the pipette. The tubes were centrifuged 3 minutes at 3000 rpm and placed back into the magnet in order to eliminate all the TE 1X. The beads were finally resuspended in 20  $\mu$ L of Laemly Buffer 1X, boiled with WCE and SUP samples 5 minutes at 95°C and loaded on acrylamide gel.

### **4.13 Neutral/Neutral 2D gel electrophoresis analysis.**

The bidimensional electrophoresis of DNA is a powerful technique used to analyze the replication intermediates (RI) on a specific DNA fragment. The signals detectable by neutral neutral bidimensional gel electrophoresis (Fig 6.2) can be described as:

. **monomer spot** = fragments of not replicated DNA: these fragments are the smallest and with the simplest structure.

. **bubble arc** = fragments from the replicative bubble generated by the firing of an active origin in the region analyzed. The bi-directional movement of the fork generates structures that increase in complexity and mass concomitantly with

replication progression.

. **Y's arc** = if the replication bubble is not perfectly in the center of the analyzed fragment or forks progress asymmetrically, a fork on one side of a bubble exits from the restriction fragment before the other, generating a structure similar to a Y. A Y-shaped RI also occurs if a region is passively replicated. Depending on the dimension, the Y-shaped molecules migrate along the big Y's or small Y's arc.

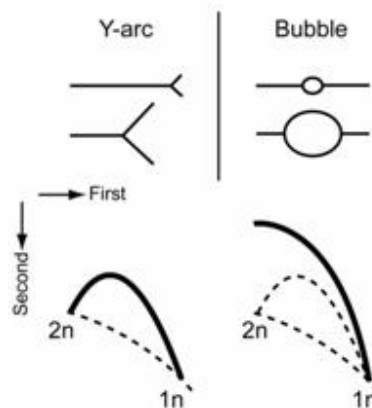

**Figure 6.2. Schematic representation of the replication intermediates detectable by 2D gel analysis.** Replication intermediates detected using the 2D gel technique. See text for details.

#### **Procedure for DNA extraction and psoralen crosslink.**

Each DNA sample was extracted starting from 200 mL of a culture at the  $1 \times 10^7$  cells/mL. Cells were treated with 2 mL of 10% Na-azide and kept on ice, from this moment on all the steps are performed in ice. After centrifuging at 5000 rpm (JA-14 Beckman tubes) for 5 minutes at 4°C and washing the pellet with 20 mL of cold water, the dry pellet was resuspended in 5 mL of ice-cold water and processed for psoralen crosslink. Psoralen intercalates in the double strand DNA and, upon irradiation with UV light (366 nm), forms covalent crosslinks between pyrimidines of opposite strands. Psoralen derivatives easily penetrate the membrane of living cells and Trimethylpsoralen (TMP) is the most commonly used for *in vivo* crosslinking of DNA (Wellinger & Sogo, 1998).

The cell suspension was transferred into a 6-well plate where we added 300 µl of 0,2 mg/mL psoralen solution, mixed well and left the plate in the dark for 5 minutes. Cells were then irradiated for 10 minutes in a stratalinker with 365 nm UV bulbs, at a distance of 2-3 centimeters from the light source. Addition of psoralen and irradiation with UV lights was repeated 3 more times with 5-minute intervals in the dark for 1-hour total time. Cells suspension was transferred in a 50 mL falcon tube and then washed twice with 5 mL of cold water to collect the remaining cells. After centrifuging 3 minutes at 4000 rpm, the pellet was dried and conserved at -20°C for DNA extraction.

For DNA extraction, 5 mL of NIB Buffer and an equal amount of autoclaved glass beads were added to the pellet; each tube was vortexed for 30 seconds at maximum speed and then put on ice for other 30 seconds; this procedure was repeated 15 times more. The supernatant was collected using *pasteur* pipettes and the beads were washed twice with 5mL of NIB Buffer. After centrifugation 10 minutes at 8000 rpm at 4°C, the pellet was resuspended in 5 mL of Buffer G2 (Quiagen Genomic DNA extraction kit) in the presence of 100 µL of RNase A 10 mg/mL and left for at least 30 minutes at 37°C. After the addition of 100 µL of Proteinase K and incubation for 1 hour at 37°C, the lysates were centrifuged at 4°C 5 minutes at 5000 rpm and the supernatant was diluted in 5 mL of QBT Buffer (Quiagen Genomic DNA extraction kit) equilibration buffer to be then loaded onto Quiagen tip 100G anion exchange columns, pre-equilibrated with 4 mL of QBT Buffer. The membrane of the columns was washed twice with 7.5 mL of QC Buffer (Quiagen Genomic DNA extraction kit) and the DNA was then eluted in corex glass tubes with 5 mL of QF Buffer (Quiagen Genomic DNA extraction kit), pre-heated at 50°C. DNA precipitation was carried out by adding 3.5 mL of isopropanol and centrifuging at 4°C 25 minutes at 8000 rpm. While the supernatant was transferred into a new corex tube and put at -20°C over night (O/N) to be centrifuged and processed the day after as just mentioned, the dry pellet was resuspended in 150 µL of sterile TE 1X, and left O/N in agitation at room temperature. The 300 µL of DNA extracted were stored at 4°C.

**DNA digestion and precipitation.**

10 or 5  $\mu\text{g}$  of DNA were digested O/N in minimum 150  $\mu\text{L}$  of final volume, in the presence of BSA 1X and the appropriate enzymes and buffers. For our analysis of DNA, we digested with 100 U of NcoI. To precipitate the digested DNA, we added to the solution 1/8 of the volume of 2.5M potassium acetate ( $\text{CH}_3\text{CO}_2\text{K}$ ) pH6 and 1 volume of isopropanol, inverted the tubes and centrifuge 10 minutes at maximum speed. The pellet was then washed with 500  $\mu\text{L}$  of 75% EtOH and, once dry, resuspended for at least 1 hour in 20  $\mu\text{L}$  of sterile TE 1X. We add 5  $\mu\text{L}$  of loading dye 20X and we load the samples.

**DNA electrophoresis.**

The gel for the first dimension was a 0.35% agarose gel in TBE 1X without ethidium bromide and it was left solidifying at 4°C for 30 minutes. This first run separates the fragments according to the mass. Before loading the samples, 20  $\mu\text{l}$  of loading dye 1X were loaded to check if the wells were intact, then we loaded the samples alternating empty wells. The first dimension was run at room temperature at 75 Volts constant for 17 hours. The first dimension gel was then stained with 0.3  $\mu\text{g}/\text{mL}$  ethidium bromide for 30 minutes, and we cut slides of appropriate dimension containing the linear and the replicated fragments. The gel slides were then placed in the second dimension gel, rotated at 90° with respect to the direction of the first dimension (Fig 6.3). The gel for the second dimension was run in conditions that maximize the effect of shape complexity: high agarose concentration (0.9%), high voltage (250 Volts) and with ethidium bromide addition (0.3  $\mu\text{g}/\text{ml}$ ). Second dimension gels were poured at RT and run at 4°C in TBE 1X buffer containing ethidium bromide (0.3  $\mu\text{g}/\text{ml}$ ), until the linear DNA line was 1 cm distance from the end of the gel (more or less 4 hours running). Starting from that point gels were then cut into 10 cm-high rectangles.

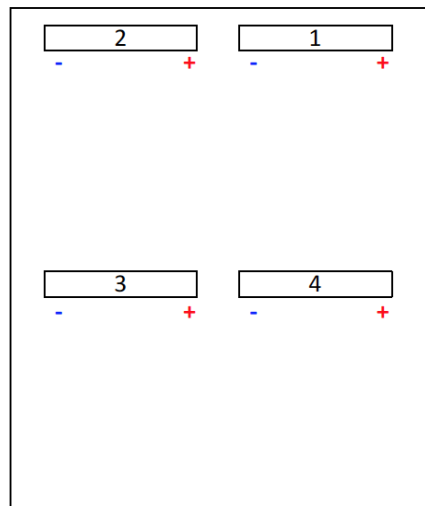

**Figure 6.3. Schematic representation of the second dimension preparation.** See text for details. – and + represent the portion of the first dimension slides with smaller and bigger DNA fragments respectively.

#### **Southern blot and hybridization procedure.**

As the DNA samples were previously treated with psoralen, before the southern blot the crosslink of the DNA was reverted by irradiating the gel for 10 minutes with 265 nM UV lamps, this treatment permits the efficient transfer of the DNA from the gel to the membrane. The gel was washed with different buffers: 5 minutes with 0.25N HCl, a fast wash in milliQ water, 30 minutes in Denaturing Solution, 30 minutes in Blot#2 solution. Meanwhile, the Gene Screen neutral transfer membrane was equilibrated in SSC 10X to be ready for the O/N blot in the same buffer. The following day, the membranes were rinsed with millQ water and then the DNA was crosslinked to the membrane by 265nm UV light. The membranes were then hybridized with the specific radiolabeled probe. 50 ng of the specific purified DNA was labeled with 50  $\mu$ Ci of  $P^{32}$  dCTP using Kleenow polymerase (Prime-a-Gene<sup>®</sup> Labeling System by Promega) which synthesizes the radiolabeled probe during 1 hour at room temperature. The probe was then purified by passing through Sephadex DNA-grade resin columns (illustra<sup>™</sup> MicroSpin<sup>™</sup> G-50 Columns by GE Healthcare) to remove the non-incorporated nucleotides. During the preparation of the radiolabeled probe, the membranes

were kept in hybridization solution 1X (PerfectHyb™ Plus Hybridisation Buffer by Sigma) for at least 1 hour at 65°C in a rotating tube. Once purified, the probe was boiled 10 minutes at 100°C, added to 30 mL of hybridization solution and left O/N rotating at 65°C. The day after, the membranes were washed as follows: 10 minutes with 50 mL of washing solution I at 65°C in the rolling tube, 15 minutes with 450 mL of washing solution I pre-heated at 65°C in a big tray shaking and twice 15 minutes with 500 mL of washing solution II pre-heated at 42°C. The IR signals were analyzed by Phosphorimager Molecular Storm and quantified using Image Quant programme.

DNA regions analyzed and oligo sequences for probe amplification are listed in the table below (Table 6.4). A schematic representation of probe localisation and the fragment recognized is presented too (Fig. 6.4)

**Table 6.4: Oligos used to amplify DNA probes for ARS305 (ChrIII 36958- 38041) analysis**

| DNA REGION  | OLIGO NAME   | SEQUENCE                   |
|-------------|--------------|----------------------------|
| ARS305      | ARS305F      | GGAGTTTGGCCACGCTCTGGC      |
| ARS305      | ARS305R      | CGCAACTACCCTAGAGCCTCTCCGCC |
| ARS305+5Kb  | ARS305+5KbF  | GGGGGAGCTTCTCCTGAAGG       |
| ARS305+5Kb  | ARS305+5KbR  | CCCAAGAGCACAAGGATTCTCCGG   |
| ARS305+15Kb | ARS305+15KbF | CCGGGATACGGACTGCGGGCGG     |
| ARS305+15Kb | ARS305+15KbR | CCCTGCGCAATTCTTAAACCACCTGC |

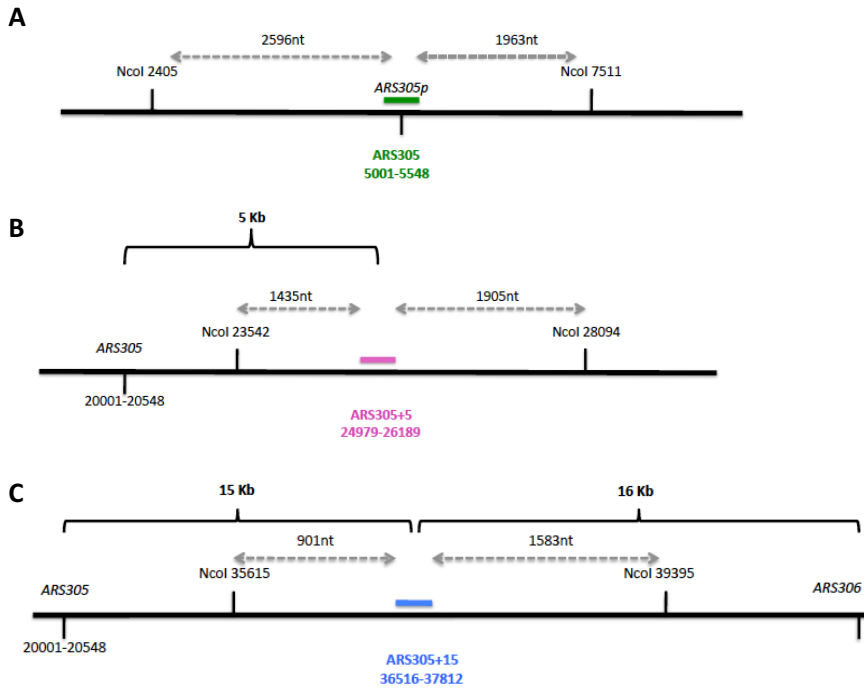

**Figure 6.4. Schematic representation of ARS305 probes.** Probe localization on the genome is presented in colors (ARS305, ARS305+5Kb, ARS305+15Kb). NcoI cut sites are present together with the size of the fragment obtained after digestion and analyzed by 2D.

## 6.14 Chromatin Immunoprecipitation (ChIP).

The term ChIP stands for chromatin immunoprecipitation and is a technique used to investigate the interaction between proteins and DNA inside the cell. This technique can be easily combined to DNA microarray labeling ("*ChIP-chip*"). ChIP-chip was here used to determine the specific location in the genome of the Bul2/Rsp5 ubiquitin complex in cells that were replicating the DNA.

Briefly, the method is as follows: protein and associated DNA were temporarily bound (crosslink with formaldehyde), the chromatin was then sheared into small fragments by sonication, cross-linked DNA fragments associated with proteins of interest (Ddc2-MYC and Bul2-PK) were selectively immunoprecipitated using appropriate antibodies, the associated DNA fragments were purified and their sequence was determined by hybridization to DNA microarrays containing the entire yeast genome sequence.

100 mL of culture at  $1 \times 10^7$  cells/mL were used for each immunoprecipitation. The culture was grown at 23°C (cell cycle = 2 hours and 30 minutes), synchronized in G1 with  $\alpha$ F and 30 minutes before the release HU was added to a final concentration of 200mM. The sample for chromatin immunoprecipitation was taken after 1-hour treatment with 200mM HU.

**1<sup>st</sup> day: antibody-bound magnetic beads preparation.**

60  $\mu$ L of magnetic beads with protein G, the same used for Co-immunoprecipitation experiments, were used each 100 mL of culture. Beads were washed twice with 1 mL of PBS 1X/BSA 5mg/mL and resuspended in the appropriate final volume of the same buffer (PBS 1X/BSA 5mg/mL). 20  $\mu$ g of anti-PK (Bul2-PK and Smc1-PK) and anti-MYC (Ddc2-MYC) antibodies were added and beads were incubated O/N in pre-lubricated Costar tubes on a wheel at 4°C. For the immunoprecipitation with HA-Rsp5 we used 120  $\mu$ L of G-protein magnetic beads and 40  $\mu$ g of anti-HA each 100 mL of culture.

**2<sup>nd</sup> day:**

- **Chromatin extracts preparation and immunoprecipitation.**

After the corresponding times of treatment with 200mM HU, cells culture were transferred into two 50 mL falcon tubes containing formaldehyde to a 1% final concentration and incubated at room temperature for 30 minutes gently shaking on a wheel. Cells were then washed 3 times by centrifuging at 3000 rpm for 3 minutes at 4°C and resuspended in 20 mL of ice-cold TBS 1X. After the last washing step, the supernatant was discarded and the remaining liquid was carefully removed with a vacuum pump. The pellets for the ChIP-qPCR were frozen O/N and processed the day after, while the pellets for ChIP-chip were directly resuspended in 0.8 mL of Lysis Buffer supplemented to 1mM PMSF and Antiproteolytic Cocktail (IP) 2X; 0.4 mL aliquots were transferred into O-ring screw-cap tubes with approximately 1 mL of glass beads. To break cells, we used the fast-prep machine alternating 5 times 30 seconds of breakage at 4 power and 5 minute on ice;

breakage time was extended if broken cells were not over 90% of the total. The recovery of the cell lysate was performed by puncturing the dry bottom each tube with a needle, and transferring the tube to a 15 mL falcon tube: before puncturing the tube it's important to unscrew the cap of the tube in order not to lose lysate once taking out the needle. The tubes were centrifuged twice 1 minute at 3000 rpm and after resuspension the flow-through was transferred to a 1.5 mL microcentrifuge tube. To discard the soluble protein fraction, the extracts were centrifuged at maximum speed for 1 minute at 4°C and a 5 µL aliquot of the soluble fraction was taken (+ 5 µL of Laemmli Buffer 2X) for Western blot analysis of IP efficiency. 0.45 mL of supplemented Lysis Buffer were added to the pellet without resuspending it: this is the starting point for DNA breakage by sonication. The chromatin was sheared by applying 5 sonication cycles of 15 seconds at 10% of power using a 250 Digital Branson Sonifier and after each sonication cycle the chromatin was pelleted by centrifuging at 5000 rpm for 1 minute at 4°C. During the sonication step, it is important to avoid sample overheating that can result in crosslink reversal. After the last sonication cycle the chromatin was pelleted at maximum speed for 5 minutes at 4°C and the supernatant was transferred to a 1.7 mL pre-lubricated Costar tube. Before adding 15.2 µL of previously washed antibody-bound magnetic beads (30.4 µL for HA-bound magnetic beads), a 5 µL aliquot of Whole Cell Extract (WCE) was taken (+ 5 µL of Laemmli Buffer 2X) for Western blot analysis of IP efficiency. The duration of the chromatin for Bul2-PK and Ddc2-MYC was 4 hours, while the immunoprecipitation of Smc1-PK and MCM7-HA was performed O/N.

- **Beads washing and crosslink reversal.**

The washing of the beads was performed on ice placing the tubes in a magnetic grid and when beads attached to the magnet the supernatant was removed with the vacuum pump. Before starting with the washes of the beads, 5 µL of the supernatant sample were transferred to a 1.5 mL eppendorf tube containing 95 µL of TE 1X-1% SDS and immediately put it on ice (**SUP** sample), meanwhile other 5

$\mu\text{L}$  of the supernatant were added to 5  $\mu\text{L}$  of Laemmli Buffer 2X for Western blot analysis of IP efficiency.

Beads were washed as follow: twice with 1 mL of ice-cold Lysis Buffer; twice with 1 mL of ice-cold Lysis Buffer supplemented with 360mM NaCl; twice with 1 mL of ice-cold Wash Buffer and a final wash with 1 mL of ice-cold TE 1X pH 8. The TE was removed with a pipette in order to avoid beads aspiration. The tubes were centrifuged at 3000 rpm for 3 minutes at 4°C, placed back in the magnetic grid and the remaining TE was removed thoroughly with a vacuum pump. We added 40  $\mu\text{L}$  of Elution Buffer to each tube and, once resuspended, the beads were incubated at 65°C for 10 minutes, flicking the tubes three times in order to resuspend beads during the incubation time. After centrifugation for 1 minute at maximum speed at room temperature, the tubes were placed back in the magnetic grid: 5  $\mu\text{L}$  of the immunoprecipated fraction (+ 5  $\mu\text{L}$  of Laemmli Buffer 2X) were taken for Western blot analysis of IP efficiency and the remaining IP fractions (35-40  $\mu\text{L}$ ) were transferred to new 1.5 mL eppendorf tube containing 4 volumes (140-160  $\mu\text{L}$ ) of TE 1X-1% SDS. Samples were then incubated O/N at 65°C to reverse the crosslink. For Western blot analysis of IP efficiency, samples were boiled at 95°C for 30 minutes and loaded on a 10% poly-acrylamide gel.

### 3<sup>rd</sup> day:

- **DNA purification.**

After consolidation by pulse-spinning, and the addition of 25  $\mu\text{L}$  of TE 1X to the sample used for the IP gel control, we added:

to **IP** samples (100  $\mu\text{L}$   $V_f$ ): 89.5  $\mu\text{L}$  TE 1X, 3  $\mu\text{L}$  glycogen (20 mg/mL), 7.5  $\mu\text{L}$  Proteinase K (50 mg/mL)

to **SUP** samples (50  $\mu\text{L}$   $V_f$ ): 44.75  $\mu\text{L}$  TE 1X, 1.5  $\mu\text{L}$  glycogen (20 mg/mL), 3.75  $\mu\text{L}$  Proteinase K (50 mg/mL)

after mixing without vortex, the samples were incubated for 2 hours at 37°C.

After sample consolidation by pulse-spin and addition of 12  $\mu\text{L}$  and 6  $\mu\text{L}$  of 5M NaCl respectively to IP and SUP samples, we extracted the DNA twice by adding an

equal volume (300  $\mu$ L for **IP** and 150  $\mu$ L for **SUP**) of phenol/chlorophorm/isoamylalcohol pH 8.0 (25:24:1 saturated with 10mM Tris, 1mM EDTA by Sigma), vortexing and centrifuging at 12000 rpm for 5 minutes at room temperature. After the second extraction we added 2 volumes of cold 100% ethanol (600  $\mu$ L for **IP** and 300  $\mu$ L for **SUP**) and samples were incubated at -20°C for at least 20 minutes or O/N. To collect the precipitated DNA, the tubes were centrifuged at maximum speed for 10 minutes at 4°C, washed with 1 mL of cold 80% Ethanol and centrifuged again at maximum speed for 5 minutes at 4°C. Once dry, the pellet was resuspended in 30  $\mu$ L of TE 1X containing 10  $\mu$ g of RNase A by vortexing and pulse-spinning three times. After incubation for 1 hour at 37°C, we pooled 30  $\mu$ L IP samples together to obtain two 60  $\mu$ L samples and purified the IP/SUP DNA using the QIAquick<sup>®</sup> PCR Purification kit from QUIAGEN and following the manufacturer's instructions. We eluted the DNA with 50  $\mu$ l of the Elution Buffer (EB) provided in the kit, later on the two IP samples were pulled together and the DNA was precipitated by adding:

to **IP** samples (100  $\mu$ L  $V_f$ ): 5  $\mu$ L 3M Sodium Acetate, 2  $\mu$ L glycogen (20 mg/mL)  
and 267.5  $\mu$ L cold 100% ethanol

to **SUP** samples (50  $\mu$ l  $V_f$ ): 2.5  $\mu$ L 3M Sodium Acetate, 1  $\mu$ L glycogen (20 mg/mL)  
and 133.75  $\mu$ L cold 100% ethanol

and left at -20°C for least 20 minutes or O/N.

Samples were then centrifuged at maximum speed for 10 minutes at 4°C, washed with 1 mL of cold 70% ethanol and centrifuged for other 5 minutes. The dry pellet was then resuspended in 10  $\mu$ L of ddH<sub>2</sub>O by vortexing and pulse-spinning three times and the DNA was transferred to a PCR tube.

- **DNA amplification**

Amplification of the SUP and IP DNA samples is required to obtain a sufficient amount ( $\geq 4/5$   $\mu$ g) of DNA to be labeled and used as hybridization probe. All the steps were performed at 4°C. We used the WGA2 GenomePlex Complete Genome Amplification (WGA) Kit (GenomePlex<sup>®</sup> Complete Whole Genome Amplification Kit by Sigma), following manufacturer's instructions from the *LIBRARY PREPARATION*

step on: we added 2  $\mu\text{L}$  of Library Preparation Buffer 1X and 1  $\mu\text{L}$  of Library Stabilization Solution to each sample (14  $\mu\text{L}$   $V_f$ ) and, once mixed by vortexing and consolidated by pulse-spinning, the tubes were placed in a thermal cycler at 95°C for 2 minutes. We then added 1  $\mu\text{L}$  of Library Preparation Enzyme, vortexed and centrifuged briefly the samples that were placed back in the thermocycler:

16°C 20'  
 24°C 20'  
 37°C 20'  
 72°C 5'  
 4°C hold

Samples were then amplified: to the 14  $\mu\text{L}$  sample we added 48.5  $\mu\text{L}$  of nuclease-free water, 7.5  $\mu\text{L}$  of Amplification Master Mix 10X, 5  $\mu\text{L}$  of WGA DNA Polymerase. After vortexing and consolidation by pulse-spin, samples were placed in the thermocycler with the following programme:

95°C 3'  
 94°C 15" } 14 cycles  
 65°C 5' }  
 4°C hold

The amplified DNA was checked by loading 1.9  $\mu\text{L}$  of the reaction in a 1.2% agarose gel, where we appreciated a smear ranging from 100 to 1000 bp.

Once amplified, the DNA was concentrated with YM30 cartridges by adding to the sample (73.1  $\mu\text{L}$ ) 427  $\mu\text{L}$  of bidistilled water and then centrifuging at 14000 g for 8 minutes. Once discarded the eluted material, we added 500  $\mu\text{L}$  of bidistilled water and centrifuged once again. We collected the concentrated volume (less than 41.75  $\mu\text{L}$ ) by inverting the column and centrifuging at 1000 g for 3 minutes. We then adjusted the final volume to 41.75  $\mu\text{L}$  and used 1  $\mu\text{L}$  for nanodrop quantification: the minimal concentration should be 50  $\mu\text{g}/\text{ml}$ . If the concentration of the sample is lower, the purified sample can be further amplified by performing 2 additional cycles of the amplification reaction. Performing more than 2 cycles may lead to unspecific amplification.

- **DNase digestion and DNA labeling.**

We first prepared DNase I reaction mix (as the volumes are very small, it's better to prepare always a final volume for 13 samples): 14.8  $\mu\text{L}$  ddH<sub>2</sub>O, 2  $\mu\text{L}$  One-Phor-All-Buffer plus 10X, 1.2  $\mu\text{L}$  25mM CoCl<sub>2</sub> and 2  $\mu\text{L}$  of DNase I (1U/mL).

Once the reaction mix was ready, we added it to the samples:

10X One-Phor-All-Buffer plus 4.85  $\mu\text{L}$

25mM CoCl<sub>2</sub> 2.9  $\mu\text{L}$

DNase I reaction mix 1.5  $\mu\text{L}$

Sample 40.75  $\mu\text{L}$

Samples were incubated at 37°C for 30 seconds and then put to 95°C for 15 minutes in the thermocycler.

The digested samples were then transferred into a new 1.5 mL eppendorf tube; we added 5  $\mu\text{L}$  of TdT reaction buffer, 1  $\mu\text{L}$  of Biotin-N11-ddATP (1nMole/mL) and 1  $\mu\text{L}$  of Terminal Transferase (400U/mL) and incubate the samples for 1 h at 37°C.

- Hybridization, washing, staining and scanning of chips (ChIP-chip), performed at IFOM's Microarray facility.

Hybridization, chip staining, washing and scanning, as well as discrimination analysis, were performed as described by the manufacture's instruction (AFFYMETRIX). In brief: chips were pre-hybridized by 200  $\mu\text{L}$  of pre-hybridization solution and incubated in an Affymetrix oven at 42° for 10-20 minutes. Meanwhile the DNA samples were prepared for hybridization:

DNA (5-10  $\mu\text{g}$ ) 55  $\mu\text{L}$

3nM control Oligo B 3,3  $\mu\text{L}$

Herring sperm DNA (10 mg/mL) 2  $\mu\text{L}$

Eukaryotic hybridization control 20X 10  $\mu\text{L}$

SSPE 20X 60  $\mu\text{L}$

0,1% Triton-X100 10  $\mu\text{L}$

ddH<sub>2</sub>O 64,7  $\mu\text{L}$

The mix was boiled for 10 minutes, transferred immediately on ice and consolidated by pulse-spin. The pre-hybridization solution was then removed and

the boiled DNA probes were spotted on micro-array chips: chips were hybridized with 15  $\mu\text{L}$  of probe for 16 hours at 42°C in a hybridization oven shaking at 60 rpm. Once removed the hybridization solution, chips were inserted in a Fluidics Station where washing (200  $\mu\text{L}$  of wash A) and staining (600  $\mu\text{L}$  staining buffer: 300  $\mu\text{L}$  Stain Buffer 2X, 270  $\mu\text{L}$  ddH<sub>2</sub>O, 24  $\mu\text{L}$  Acetylated BSA 50 mg/mL, 6  $\mu\text{L}$  SAPE 1 mg/mL) protocols provided by Affymetrix were performed.

Chips were then scanned and signal intensities of each locus on DNA chips hybridized with IP or SUP fractions were compared using GCOS expression analysis. Discrimination analysis was carried out using statistical algorithms developed by Affymetrix according to the manufacturer's instruction.

### 6.15 Sister Chromatid Exchange assay (SCE)

Sister chromatid exchange (SCE) is the exchange of genetic material between two identical sister chromatids. To measure the frequency of these events on exponentially growing cells, Lorrain Symington's laboratory constructed a simple and effective system based on the insertion of a direct-repeat recombination substrate containing 3.6 kb copies bearing different *ade2* mutated alleles (***ade2-n*** and ***ade2-1***) integrated at the endogenous *ADE2* locus and separated by plasmid sequence and a *TRP1* gene (for plasmid construction details see Huang & Symington, 1994). Recombination between the two *ade2* genes can produce a wild-type copy of *ADE2*. This can occur by a **pop-out** mechanism, resulting in loss of the intervening *TRP1* gene, or by **gene conversion**, in which the *TRP1* gene is retained. **Gene conversion** events (Fig. 6.5) by sister chromatid recombination were measured and recombination frequencies were then calculated.

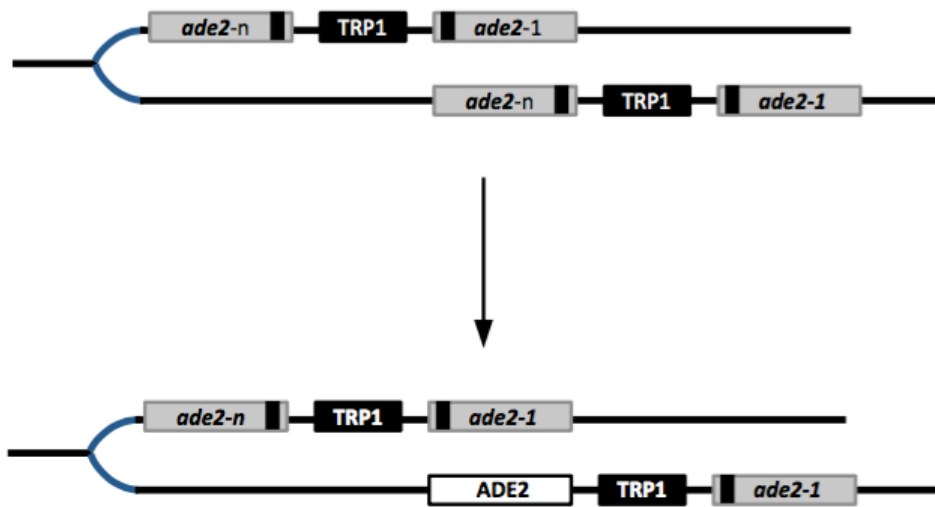

**Figure 6.5. Schematic representation of SCE recombination substrate and gene conversion product.** The integrated SCE plasmid contains two *ade2* mutated alleles (*ade2-n* and *ade2-1*, grey) whose mutations are represented as a black bar inside the gene at the C-term and N-term respectively. The two alleles are integrated at the endogenous *ADE2* locus, on chromosome XV (566191...564476), and are separated by plasmid sequence and *TRP1* gene (black). Adapted from Mozlin et al., 2008).

To determine the rate of adenine prototroph formation, WT and *bul1Δ bul2Δ* cells carrying the integrated SCE system, were first streaked at 30°C on YPD plates and a single red colony (*ade2*) was then picked and dispersed in 1 mL of H<sub>2</sub>O. 10-fold serial dilutions of the cell suspension were prepared and 50 μL of 10<sup>-3</sup> and 10<sup>-4</sup> dilutions were plated on YPD or 20 mM HU YPD plates for each strain analysed. Three days later 9 independent red colonies were picked, resuspended in 200 μL of H<sub>2</sub>O in wells of 96-well plates and 10-fold serial dilutions were prepared out to 10<sup>-5</sup>. 50 μL of undiluted, 10<sup>-1</sup> and 10<sup>-2</sup> dilutions were plated on SC-Ade plates to select for recombinants, while 50 μL of 10<sup>-4</sup> and 10<sup>-5</sup> dilutions on SC (+Ade) plates for total cell count. After three days, cells grown on SC and SC-Ade plates were counted: the total number of cell (cfu = cell forming units, cells grown on SC

plates) and adenine prototroph recombinants (*ADE2* cells grown on SC-Ade plates) for each of the 9 colonies were determined (**n.colonies on plate x 4 x dilution plated**). To measure gene conversion events, cells grown on SC-Ade plates were replicaplated on  $-TRP$  plates and the number of colonies (GeneConversion\_recombinants) grown was the number used to calculate the frequency of sister chromatid recombination events (**n. GC\_recombinats x 100/total cfu**). Once determined the frequency for each of the 9 colonies, we used the median value to determine the sister chromatid recombination rate/cell /generation applying the Drake formula:

$$\text{rate: } (0.4343 \times \text{median frequency}) / (\log N - \log N_0)$$

where **N** is the total number of cells present in the colony and **N<sub>0</sub>** is the number of initial cells, which is 1 because each colony was derived from a single cell.

### 6.16 Ni-NTA affinity chromatography (His-Pull Down).

In Pulls Down assay, a bait protein is tagged and captured on an immobilized affinity ligand specific for the tag thereby generating a "secondary affinity support" for purifying other proteins that interact with the bait protein. We used this technique to pull down ubiquitilated proteins using as bait protein a Ubiquitin tagged with Histidine (<sup>His</sup>Ub) and as immobilized ligand a Nickel Sepharose resin (Ni Sepharose™ 6 Fast Flow by GE Healthcare) which has affinity for HIS-tagged proteins. For our pull down experiments total ubiquitin conjugates were isolated from strains carrying an His<sub>7</sub>-tagged ubiquitin under regulatory control of the copper metallothionein (*CUP1*) promoter (Fig. 6.6 and for further details Stelter & Ulrich, 2003). Episomal plasmids bearing *URA3* gene (YEplac195) was used to overexpress His<sub>7</sub>-tagged ubiquitin, while an empty plasmid served as control. Total cell extracts were prepared under denaturing condntions and the purified ubiquitilated proteins were then analysed by SDS-polyacrylamide gel electrophoresis and western blotting using the specific monoclonal antibody against the protein of interest (Ddc2-MYC).

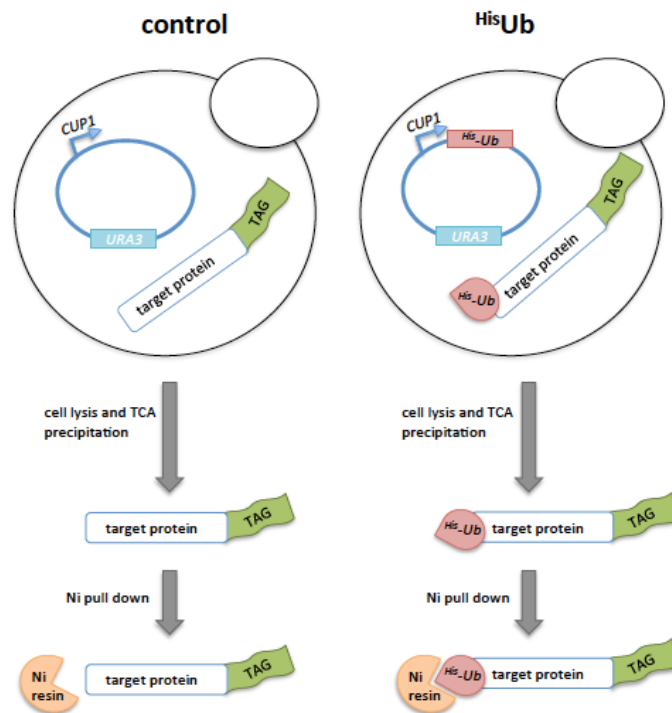

**Figure 6.5. Schematic representation of the principles of a <sup>His</sup>Ubiquitin Pull Down.**

Plasmids *YEplac195-CUP1* (control) and *YEplac-CUP1-HIS7-UB* (<sup>His</sup>Ub) are schematically represented: *URA3* selective marker, *CUP1* inducible promoter and His-tagged ubiquitin in the case of *YEplac-CUP1-HIS7-UB* plasmid. After cell lysis and TCA precipitation, the extracts are incubated in the presence of a nickel resin with high affinity for histidine. The pull down only purifies proteins carrying the His-tagged ubiquitin version. See text for details.

A 100 mL culture was grown at 30°C to a final concentration of  $1 \times 10^7$  cells/mL in selective -URA medium in order not to lose the plasmids. Cells were synchronised in G1 with  $\alpha$ F and the expression of <sup>His</sup>Ub was induced since the beginning of the experiment by adding 1  $\mu$ L of 100mM CuSO<sub>4</sub> per 1 mL of culture. After 2-hour treatment with 200 mM HU in the presence of CuSO<sub>4</sub>, cells were collected in 50 mL falcon tubes and centrifuged 2 minutes at 3000 rpm. After a wash with cold water, the pellet was transferred into an O-ring tube and spun 10 seconds at maximum speed. The pellet was then resuspend by vortex in 500  $\mu$ L of 12% TCA,

spinned again, resuspended in 500  $\mu$ L of 1M Tris-HCl pH 8.0 and spinned for a third time. After removing the supernatant, the obtained pellet was frozen at -80°C for at least 30 minutes. Without defreezing the pellet, we added 250  $\mu$ L of freshly prepared Buffer A supplemented by Protease Inhibitor (IP) 1X and 500  $\mu$ L of glass beads. Cells were broken in the fast-prep machine power 6 for 40 seconds. Once checked the breakage, the supernatant was recovered in 1.5 mL eppendorf tubes and 750  $\mu$ L of Buffer A + IP 1X was added to each tube. After a 10-minute centrifugation at maximum speed, the supernatant was collected and quantified using a spectrophotometer. Samples were normalized to the lowest concentrated one and 17  $\mu$ L (+ 17  $\mu$ L of SSR 2X) from the whole cell extract were used as INPUT sample for the western blot analysis. Meanwhile 50  $\mu$ L of Ni resin were washed twice with 900  $\mu$ L of Buffer A (1 minutes at 3400 rpm) in pre-lubricated Costar tubes. Finally, the normalized samples were incubated with the resin O/N on a wheel at RT in the presence of 15mM imidazole. The day after the tubes were spinned 1 minutes at 3400 rpm, the supernatant carefully removed and the resin was washed as follow: 900  $\mu$ L of freshly prepared Buffer C, twice 900  $\mu$ L of Buffer A supplemented with 2mM imidazole and three times 900  $\mu$ L of Buffer C. Each wash was followed by a 10-minute incubation on a wheel at RT and a spin of 1 minute at 3400 rpm. The washed resin was then resuspended in 25  $\mu$ L of SSR 2X and proteins are eluted in the buffer by shaking at 400 rpm for 3 minutes at 95°C. Samples were centrifuged 5 minutes at maximum speed and the supernatant was collected to be stored at -20°C or directly loaded on a 10% acrylamide SDS-PAGE gel.

### **6.17 Deep sequencing**

To study replication defects genome wide we implemented a technique set up in Shirahige's laboratory to follow replication origin firing (Müller et al., 2014). DNA was extracted as previously described for 2D gel. Cells were grown, arrested and released at 30°C into 200mM HU. Samples were taken in G1 and after 30 minutes, 1, 2, 3 and 4 hours after treatment with HU. Cell pellets were resuspended in 5

mL cold NIB buffer. After the addition of a similar volume of glass beads, samples were vortexed vigorously for 30 seconds, followed by 30 seconds cooling in ice. The vortex-cooling cycle was repeated 16 times. The extract was recovered from the glass beads and gently resuspended in 5 mL G2 buffer (QIAGEN). Samples were treated with RNase A and proteinase K followed by centrifugation. The supernatant was supplemented with 5 mL QBT buffer (QIAGEN) and then purified using equilibrated QIAGEN Genomic-Tips 100/G according to manufacturers' instructions. The DNA is resuspended in 150  $\mu$ L TE 1X and quantified by nanodrop. 3  $\mu$ g of DNA were at Shirahige's Laboratory.

To generate replication profiles, the ratio of uniquely mapped reads in the S-phase samples to G1 DNA was calculated. Custom Perl scripts were used to independently calculate this ratio. For each of the time point, the DNA copy number was calculated relative to G1-phase. Orange and red peaks in each time point represent genomic locations that show signals 1.2 or 1.5 higher than G1 sequences.

# Bibliography

- Aguilera, A., & Gómez-González, B. (2008). Genome instability: a mechanistic view of its causes and consequences. *Nature Reviews. Genetics*, *9*(3), 204–217. <http://doi.org/10.1038/nrg2268>
- Alcasabas, A., Osborn, J., Bachant, J., Hu, F., Werler, P. J., Bousset, K., ... Elledge, S. J. (2001). Mrc1 transduces signals of DNA replication stress to activate Rad53. *Nature Cell Biology*, *3*(11), 958–65. <http://doi.org/10.1038/ncb1101-958>
- Almedawar, S., Colomina, N., Bermúdez-López, M., Pociño-Merino, I., & Torres-Rosell, J. (2012). A SUMO-dependent step during establishment of sister chromatid cohesion. *Current Biology*, *22*(17), 1576–1581. <http://doi.org/10.1016/j.cub.2012.06.046>
- Álvarez, V., Viñas, L., Gallego-Sánchez, A., Andrés, S., Sacristán, M. P., & Bueno, A. (2016). Orderly progression through S-phase requires dynamic ubiquitylation and deubiquitylation of PCNA. *Scientific Reports*, *6*(April), 25513. <http://doi.org/10.1038/srep25513>
- Amerik, A. Y., & Hochstrasser, M. (2004). Mechanism and function of deubiquitinating enzymes. *Biochimica et Biophysica Acta - Molecular Cell Research*, *1695*(1-3), 189–207. <http://doi.org/10.1016/j.bbamcr.2004.10.003>
- Andoh, T., Hirata, Y., & Kikuchi, A. (2000). Yeast glycogen synthase kinase 3 is involved in protein degradation in cooperation with Bul1, Bul2, and Rsp5. *Molecular and Cellular Biology*, *20*(18), 6712–20. Retrieved from <http://www.pubmedcentral.nih.gov/articlerender.fcgi?artid=86186&tool=pmcentrez&rendertype=abstract>
- Arumugam, P., Gruber, S., Tanaka, K., Haering, C. H., Mechtler, K., & Nasmyth, K. (2003). ATP Hydrolysis Is Required for Cohesin's Association with Chromosomes. *Current Biology*, *13*(22), 1941–1953. <http://doi.org/10.1016/j.cub.2003.10.036>
- Arumugam, P., Nishino, T., Haering, C. H., Gruber, S., & Nasmyth, K. (2006). Cohesin's ATPase Activity Is Stimulated by the C-Terminal Winged-Helix Domain of Its Kleisin Subunit. *Current Biology*, *16*(20), 1998–2008. <http://doi.org/10.1016/j.cub.2006.09.002>
- Balakirev, M. Y., Mullally, J. E., Favier, A., Assard, N., Sulpice, E., Lindsey, D. F., ... Wilkinson, K. D. (2015). Wss1 metalloprotease partners with Cdc48/Doa1 in processing genotoxic SUMO conjugates. *eLife*, *4*(September2015), 1–30. <http://doi.org/10.7554/eLife.06763>
- Beckouët, F., Hu, B., Roig, M. B., Sutani, T., Komata, M., Uluocak, P., ... Nasmyth, K. (2010). An Smc3 Acetylation Cycle Is Essential for Establishment of Sister Chromatid Cohesion. *Molecular Cell*, *39*(5), 689–699. <http://doi.org/10.1016/j.molcel.2010.08.008>
- Beckouët, F., Srinivasan, M., Roig, M. B., Chan, K. L., Scheinost, J. C., Batty, P., ... Nasmyth, K. (2016). Releasing Activity Disengages Cohesin's Smc3/Sccl Interface in a Process Blocked by Acetylation. *Molecular Cell*, *61*(4), 563–574. <http://doi.org/10.1016/j.molcel.2016.01.026>
- Bergink, S., & Jentsch, S. (2009). Principles of ubiquitin and SUMO modifications in DNA repair. *Nature*, *458*(7237), 461–7. <http://doi.org/10.1038/nature07963>
- Bienko, M. (2005). Ubiquitin-Binding Domains in Y-Family Polymerases Regulate

- Translesion Synthesis. *Science*, 310(5755), 1821–1824. <http://doi.org/10.1126/science.1120615>
- Blow, J. J. (1993). Preventing Re-replication of DNA in a single cell cycle: Evidence for a replication licensing factor. *J. Cell. Biol.*, 122(5), 993–1002.
- Blow, J. J., & Dutta, A. (2009). Europe PMC Funders Group Preventing re-replication of chromosomal DNA, 6(6), 476–486. <http://doi.org/10.1038/nrm1663>
- Blow, J. J., & Tanaka, T. U. (2005). The chromosome cycle: coordinating replication and segregation. Second in the cycles review series. *EMBO Reports*, 6(11), 1028–34. <http://doi.org/10.1038/sj.embor.7400557>
- Brachmann, C. B., Davies, a, Cost, G. J., Caputo, E., Li, J., Hieter, P., & Boeke, J. D. (1998). Designer deletion strains derived from *Saccharomyces cerevisiae* S288C: a useful set of strains and plasmids for PCR-mediated gene disruption and other applications. *Yeast (Chichester, England)*, 14(2), 115–32. [http://doi.org/10.1002/\(SICI\)1097-0061\(19980130\)14:2<115::AID-YEA204>3.0.CO;2-2](http://doi.org/10.1002/(SICI)1097-0061(19980130)14:2<115::AID-YEA204>3.0.CO;2-2)
- Brandman, O., Stewart-Ornstein, J., Wong, D., Larson, A., Williams, C. C., Li, G.-W., ... Weissman, J. S. (2012). A ribosome-bound quality control complex triggers degradation of nascent peptides and signals translation stress. *Cell*, 151(5), 1042–54. <http://doi.org/10.1016/j.cell.2012.10.044>
- Branzei, D., & Foiani, M. (2005). The DNA damage response during DNA replication. *Current Opinion in Cell Biology*, 17(6), 568–575. <http://doi.org/10.1016/j.ceb.2005.09.003>
- Branzei, D., & Foiani, M. (2009). The checkpoint response to replication stress. *DNA Repair (Amst)*, 8(9), 1038–1046. <http://doi.org/10.1016/j.dnarep.2009.04.014>
- Braun, S., Matuschewski, K., Rape, M., Thoms, S., & Jentsch, S. (2002). Role of the ubiquitin-selective CDC48UFD1/NPL4 chaperone (segregase) in ERAD of OLE1 and other substrates. *EMBO Journal*, 21(4), 615–621. <http://doi.org/10.1093/emboj/21.4.615>
- Broomfield, S., Chow, B. L., & Xiao, W. (1998). MMS2, encoding a ubiquitin-conjugating-enzyme-like protein, is a member of the yeast error-free postreplication repair pathway. *Proceedings of the National Academy of Sciences*, 95(10), 5678–5683. <http://doi.org/10.1073/pnas.95.10.5678>
- Buchan, J. R., Kolaitis, R., Taylor, J. P., & Parker, R. (2013). Eukaryotic Stress Granules Are Cleared by Autophagy and Cdc48 / VCP Function. *Cell*, 153(7), 1461–1474. <http://doi.org/10.1016/j.cell.2013.05.037>
- Byun, T. S., Pacek, M., Yee, M. C., Walter, J. C., & Cimprich, K. A. (2005). Functional uncoupling of MCM helicase and DNA polymerase activities activates the ATR-dependent checkpoint. *Genes and Development*, 19(9), 1040–1052. <http://doi.org/10.1101/gad.1301205>
- Centore, R. C., Yazinski, S. A., Tse, A., & Zou, L. (2012). Spartan/C1orf124, a Reader of PCNA Ubiquitylation and a Regulator of UV-Induced DNA Damage Response. *Molecular Cell*, 46(5), 625–635. <http://doi.org/10.1016/j.molcel.2012.05.020>
- Chan, K. L., Roig, M. B., Hu, B., Beckouët, F., Metson, J., & Nasmyth, K. (2012). Cohesin's DNA exit gate is distinct from its entrance gate and is regulated by acetylation. *Cell*, 150(5), 961–974. <http://doi.org/10.1016/j.cell.2012.07.028>
- Chan, K.-L., Gligoris, T., Upcher, W., Kato, Y., Shirahige, K., Nasmyth, K., & Beckouët, F. (2013). Pds5 promotes and protects cohesin acetylation. *Proceedings of the*

- National Academy of Sciences*, 110(32), 13020–13025.  
<http://doi.org/10.1073/pnas.1306900110>
- Chen, S. H., Albuquerque, C. P., Liang, J., Suhandynata, R. T., & Zhou, H. (2010). A proteome-wide analysis of kinase-substrate network in the DNA damage response. *Journal of Biological Chemistry*, 285(17), 12803–12812.  
<http://doi.org/10.1074/jbc.M110.106989>
- Ciosk, R., Zachariae, W., Michaelis, C., Shevchenko, A., Mann, M., & Nasmyth, K. (1998). An ESP1/PDS1 complex regulates loss of sister chromatid cohesion at the metaphase to anaphase transition in yeast. *Cell*, 93(6), 1067–1076.  
[http://doi.org/10.1016/S0092-8674\(00\)81211-8](http://doi.org/10.1016/S0092-8674(00)81211-8)
- Cobb, J. A., Schleker, T., Rojas, V., Bjergbaek, L., Tercero, J. A., & Gasser, S. M. (2005). Replisome instability, fork collapse, and gross chromosomal rearrangements arise synergistically from Mec1 kinase and RecQ helicase mutations. *Genes and Development*, 19(24), 3055–3069. <http://doi.org/10.1101/gad.361805>
- Cortés-Ledesma, F., & Aguilera, A. (2006). Double-strand breaks arising by replication through a nick are repaired by cohesin-dependent sister-chromatid exchange. *EMBO Reports*, 7(9), 919–926. <http://doi.org/10.1038/sj.embor.7400774>
- Crapeau, M., Merhi, A., & Andre, B. (2014). Stress Conditions Promote Yeast Gap1 Permease Ubiquitylation and Downregulation via the Arrestin-like Bul and Aly Proteins. *The Journal of Biological Chemistry*.  
<http://doi.org/10.1074/jbc.M114.582320>
- Crespo, J. L., Helliwell, S. B., Wiederkehr, C., Demougin, P., Fowler, B., Primig, M., & Hall, M. N. (2004). NPR1 kinase and RSP5-BUL1/2 ubiquitin ligase control GLN3-dependent transcription in *Saccharomyces cerevisiae*. *J Biol Chem*, 279(36), 37512–37517. <http://doi.org/10.1074/jbc.M407372200>
- Dantuma, N. P., Acs, K., & Luijsterburg, M. S. (2014). Should I stay or should I go: VCP/p97-mediated chromatin extraction in the DNA damage response. *Experimental Cell Research*, 329(1), 9–17.  
<http://doi.org/10.1016/j.yexcr.2014.08.025>
- Deardorff, M. A., Kaur, M., Yaeger, D., Rampuria, A., Korolev, S., Pie, J., ... Krantz, I. D. (2007). Mutations in Cohesin Complex Members SMC3 and SMC1A Cause a Mild Variant of Cornelia de Lange Syndrome with Predominant Mental Retardation, 80(March), 485–494. <http://doi.org/10.1086/511888>
- DePamphilis, M. L., Blow, J. J., Ghosh, S., Saha, T., Noguchi, K., & Vassilev, A. (2006). Regulating the licensing of DNA replication origins in metazoa. *Current Opinion in Cell Biology*, 18(3), 231–239. <http://doi.org/10.1016/j.ceb.2006.04.001>
- Deshaies, R. J., & Joazeiro, C. a P. (2009). RING domain E3 ubiquitin ligases. *Annual Review of Biochemistry*, 78, 399–434.  
<http://doi.org/10.1146/annurev.biochem.78.101807.093809>
- Diffley, J. F., & Cocker, J. H. (1992). Protein-DNA interactions at a yeast replication origin. *Nature*, 357(6374), 169–172. <http://doi.org/10.1038/357169a0>
- Diffley, J. F. X., Cocker, J. H., Dowell, S. J., & Rowley, A. (1994). Two steps in the assembly of complexes at yeast replication origins in vivo. *Cell*, 78(2), 303–316.  
[http://doi.org/10.1016/0092-8674\(94\)90299-2](http://doi.org/10.1016/0092-8674(94)90299-2)
- Dikic, I., Wakatsuki, S., & Walters, K. J. (2009). Ubiquitin-binding domains - from structures to functions. *Nature Reviews. Molecular Cell Biology*, 10(10), 659–671.  
<http://doi.org/10.1038/nrm2767>

- Doil, C., Mailand, N., Bekker-Jensen, S., Menard, P., Larsen, D. H., Pepperkok, R., ... Lukas, C. (2009). RNF168 Binds and Amplifies Ubiquitin Conjugates on Damaged Chromosomes to Allow Accumulation of Repair Proteins. *Cell*, *136*(3), 435–446. <http://doi.org/10.1016/j.cell.2008.12.041>
- Donovan, S., Harwood, J., Drury, L. S., & Diffley, J. F. (1997). Cdc6p-dependent loading of Mcm proteins onto pre-replicative chromatin in budding yeast. *Proceedings of the National Academy of Sciences of the United States of America*, *94*(11), 5611–6. <http://doi.org/10.1073/pnas.94.11.5611>
- Dunn, R., Klos, D. A., Adler, A. S., & Hicke, L. (2004). The C2 domain of the Rsp5 ubiquitin ligase binds membrane phosphoinositides and directs ubiquitination of endosomal cargo. *Journal of Cell Biology*, *165*(1), 135–144. <http://doi.org/10.1083/jcb.200309026>
- Elia, A. E. H., Wang, D. C., Willis, N. A., Boardman, A. P., Hajdu, I., Adeyemi, R. O., ... Elledge, S. J. (2015). RFW3-Dependent Ubiquitination of RPA Regulates Repair at Stalled Replication Forks. *Molecular Cell*, *60*(2), 280–293. <http://doi.org/10.1016/j.molcel.2015.09.011>
- Erdeniz, N., & Rothstein, R. (2000). Rsp5, a ubiquitin-protein ligase, is involved in degradation of the single-stranded-DNA binding protein rfa1 in *Saccharomyces cerevisiae*. *Molecular and Cellular Biology*, *20*(1), 224–32. Retrieved from <http://www.pubmedcentral.nih.gov/articlerender.fcgi?artid=85078&tool=pmcentrez&rendertype=abstract>
- Fang, L., Hemion, C., Pinho Ferreira Bento, A. C., Bippes, C. C., Flammer, J., & Neutzner, A. (2015). Mitochondrial function in neuronal cells depends on p97/VCP/Cdc48-mediated quality control. *Frontiers in Cellular Neuroscience*, *9*(February), 16. <http://doi.org/10.3389/fncel.2015.00016>
- Fernius, J., & Marston, A. L. (2009). Establishment of cohesion at the pericentromere by the Ctf19 kinetochore subcomplex and the replication fork-associated factor, Csm3. *PLoS Genetics*, *5*(9). <http://doi.org/10.1371/journal.pgen.1000629>
- Franz, A., Orth, M., Pirson, P. A., Sonnevill, R., & Blow, J. J. (2012). CDC-48 / p97 Coordinates CDT-1 Degradation with GINS Chromatin Dissociation to Ensure Faithful DNA Replication, *44*(1), 85–96. <http://doi.org/10.1016/j.molcel.2011.08.028.CDC-48/p97>
- Franz, A., Pirson, P. A., Pilger, D., Halder, S., Achuthankutty, D., Kashkar, H., ... Hoppe, T. (2016). Chromatin-associated degradation is defined by UBXN-3/FAF1 to safeguard DNA replication fork progression. *Nature Communications*, *7*, 10612. <http://doi.org/10.1038/ncomms10612>
- Gallego-Sánchez, A., Andrés, S., Conde, F., San-Segundo, P. A., & Bueno, A. (2012). Reversal of PCNA ubiquitylation by Ubp10 in *Saccharomyces cerevisiae*. *PLoS Genetics*, *8*(7). <http://doi.org/10.1371/journal.pgen.1002826>
- Gambus, A., Jones, R. C., Sanchez-diaz, A., Kanemaki, M., van Deursen, F., Edmondson, R. D., ... Deursen, F. Van. (2006). GINS maintains association of Cdc45 with MCM in replisome progression complexes at eukaryotic DNA replication forks. *Nature Cell Biology*, *8*(4), 358–366. <http://doi.org/10.1038/ncb1382>
- Gandhi, R., Gillespie, P. J., & Hirano, T. (2006). Human Wapl Is a Cohesin-Binding Protein that Promotes Sister-Chromatid Resolution in Mitotic Prophase. *Current Biology*, *16*(24), 2406–2417. <http://doi.org/10.1016/j.cub.2006.10.061>
- Gligoris, T. G., Scheinost, J. C., Bürmann, F., Petela, N., Chan, K., Uluocak, P., ... Löwe, J.

- (n.d.). Closing the cohesin ring: Structure and function of its Smc3-kleisin interface, 963–968.
- González-Barrera, S., Cortés-Ledesma, F., Wellinger, R. E., & Aguilera, A. (2003). Equal sister chromatid exchange is a major mechanism of double-strand break repair in yeast. *Molecular Cell*, *11*(6), 1661–1671. [http://doi.org/10.1016/S1097-2765\(03\)00183-7](http://doi.org/10.1016/S1097-2765(03)00183-7)
- Gruber, S., Arumugam, P., Katou, Y., Kuglitsch, D., Helmhart, W., Shirahige, K., & Nasmyth, K. (2006). Evidence that Loading of Cohesin Onto Chromosomes Involves Opening of Its SMC Hinge. *Cell*, *127*(3), 523–537. <http://doi.org/10.1016/j.cell.2006.08.048>
- Gruber, S., Haering, C. H., & Nasmyth, K. (2003). Chromosomal cohesin forms a ring. *Cell*, *112*(6), 765–777. [http://doi.org/10.1016/S0092-8674\(03\)00162-4](http://doi.org/10.1016/S0092-8674(03)00162-4)
- Guillou, E., Ibarra, A., Coulon, V., Casado-vela, J., Rico, D., Casal, I., ... Me, J. (2010). Cohesin organizes chromatin loops at DNA replication factories, 2812–2822. <http://doi.org/10.1101/gad.608210.6>
- Gupta, R., Kus, B., Fladd, C., Wasmuth, J., Tonikian, R., Sidhu, S., ... Rotin, D. (2007). Ubiquitination screen using protein microarrays for comprehensive identification of Rsp5 substrates in yeast. *Mol Syst Biol*, *3*, 116. <http://doi.org/10.1038/msb4100159>
- Gwizdek, C., Hobeika, M., Kus, B., Ossareh-Nazari, B., Dargemont, C., & Rodriguez, M. S. (2005). The mRNA nuclear export factor Hpr1 is regulated by Rsp5-mediated ubiquitylation. *The Journal of Biological Chemistry*, *280*(14), 13401–5. <http://doi.org/10.1074/jbc.C500040200>
- Haering, C. H., Farcas, A.-M., Arumugam, P., Metson, J., & Nasmyth, K. (2008). The cohesin ring concatenates sister DNA molecules. *Nature*, *454*(7202), 297–301. <http://doi.org/10.1038/nature07098>
- Haering, C. H., Löwe, J., Hochwagen, A., & Nasmyth, K. (2002). Molecular architecture of SMC proteins and the yeast cohesin complex. *Molecular Cell*, *9*(4), 773–788. [http://doi.org/10.1016/S1097-2765\(02\)00515-4](http://doi.org/10.1016/S1097-2765(02)00515-4)
- Hanna, J. S., Kroll, E. S., Lundblad, V., & Spencer, F. a. (2001). Are Required for Sister Chromatid Cohesion *Saccharomyces cerevisiae* CTF18 and CTF4 Are Required for Sister Chromatid Cohesion, *21*(9), 3144–3158. <http://doi.org/10.1128/MCB.21.9.3144>
- Hara, K., Zheng, G., Qu, Q., Liu, H., Ouyang, Z., Chen, Z., ... Yu, H. (2014). Structure of cohesin subcomplex pinpoints direct shugoshin-Wapl antagonism in centromeric cohesion. *Nature Structural & Molecular Biology*, *21*(10), 864–70. <http://doi.org/10.1038/nsmb.2880>
- Harreman, M., Taschner, M., Sigurdsson, S., Anindya, R., Reid, J., Somesh, B., ... Svejstrup, J. Q. (2009). Distinct ubiquitin ligases act sequentially for RNA polymerase II polyubiquitylation. *Proceedings of the National Academy of Sciences of the United States of America*, *106*(49), 20705–20710. <http://doi.org/10.1073/pnas.0907052106>
- Heller, R. C., Kang, S., Lam, W. M., Chen, S., Chan, C. S., & Bell, S. P. (2011). Eukaryotic origin-dependent DNA replication in vitro reveals sequential action of DDK and S-CDK kinases. *Cell*, *146*(1), 80–91. <http://doi.org/10.1016/j.cell.2011.06.012>
- Helliwell, S. B., Losko, S., & Kaiser, C. a. (2001). Components of a ubiquitin ligase complex specify polyubiquitination and intracellular trafficking of the general

- amino acid permease. *The Journal of Cell Biology*, 153(4), 649–62. Retrieved from <http://www.pubmedcentral.nih.gov/articlerender.fcgi?artid=2192387&tool=pmc-entrez&rendertype=abstract>
- Hemion, C., Flammer, J., & Neutzner, A. (2014). Quality control of oxidatively damaged mitochondrial proteins is mediated by p97 and the proteasome. *Free Radical Biology and Medicine*, 75, 121–128. <http://doi.org/10.1016/j.freeradbiomed.2014.07.016>
- Hirano, M., & Hirano, T. (2006). Opening closed arms: Long-distance activation of SMC ATPase by hinge-DNA interactions. *Molecular Cell*, 21(2), 175–186. <http://doi.org/10.1016/j.molcel.2005.11.026>
- Hoege, C., Pfander, B., Moldovan, G.-L., Pyrowolakis, G., & Jentsch, S. (2002). RAD6-dependent DNA repair is linked to modification of PCNA by ubiquitin and SUMO. *Nature*, 419(6903), 135–141. <http://doi.org/10.1038/nature00991>
- Hoppe, T. (2005). Multiubiquitylation by E4 enzymes: “One size” doesn’t fit all. *Trends in Biochemical Sciences*, 30(4), 183–187. <http://doi.org/10.1016/j.tibs.2005.02.004>
- Hoppe, T., Matuschewski, K., Rape, M., Schlenker, S., Ulrich, H. D., & Jentsch, S. (2000). Activation of a membrane-bound transcription factor by regulated ubiquitin/proteasome-dependent processing. *Cell*, 102(5), 577–86. Retrieved from <http://www.ncbi.nlm.nih.gov/pubmed/11007476>
- Huang, K. N., & Symington, L. S. (1994). Mutation of the gene encoding protein kinase C 1 stimulates mitotic recombination in *Saccharomyces cerevisiae*. *Molecular and Cellular Biology*, 14(9), 6039–45. Retrieved from <http://www.pubmedcentral.nih.gov/articlerender.fcgi?artid=359130&tool=pmc-entrez&rendertype=abstract>
- Huang, T. T., Nijman, S. M. B., Mirchandani, K. D., Galardy, P. J., Cohn, M. a, Haas, W., ... D’Andrea, A. D. (2006). Regulation of monoubiquitinated PCNA by DUB autocleavage. *Nature Cell Biology*, 8(4), 339–347. <http://doi.org/10.1038/ncb1378>
- Huibregtse, J. M., Yang, J. C., & Beaudenon, S. L. (1997). The large subunit of RNA polymerase II is a substrate of the Rsp5 ubiquitin-protein ligase. *Proceedings of the National Academy of Sciences of the United States of America*, 94(8), 3656–61. Retrieved from <http://www.pubmedcentral.nih.gov/articlerender.fcgi?artid=20496&tool=pmc-entrez&rendertype=abstract>
- Ilves, I., Petojevic, T., Pesavento, J. J., & Botchan, M. R. (2010). Activation of the MCM2-7 Helicase by Association with Cdc45 and GINS Proteins. *Molecular Cell*, 37(2), 247–258. <http://doi.org/10.1016/j.molcel.2009.12.030>
- Jarosch, E., Taxis, C., Volkwein, C., Bordallo, J., Finley, D., Wolf, D. H., & Sommer, T. (2002). Protein dislocation from the ER requires polyubiquitination and the AAA-ATPase Cdc48. *Nature Cell Biology*, 4(2), 134–139. <http://doi.org/10.1038/ncb746>
- Johansson, E., Garg, P., & Burgers, P. M. J. (2004). The Pol32 Subunit of DNA Polymerase ?? Contains Separable Domains for Processive Replication and Proliferating Cell Nuclear Antigen (PCNA) Binding. *Journal of Biological Chemistry*, 279(3), 1907–1915. <http://doi.org/10.1074/jbc.M310362200>
- Jossen, R., & Bermejo, R. (2013). The DNA damage checkpoint response to replication stress: A Game of Forks. *Front Genet*, 4, 26. <http://doi.org/10.3389/fgene.2013.00026>

- Kaida, D., Toh-e, A., & Kikuchi, Y. (2003). Rsp5–Bul1/2 complex is necessary for the HSE-mediated gene expression in budding yeast. *Biochemical and Biophysical Research Communications*, 306(4), 1037–1041. [http://doi.org/10.1016/s0006-291x\(03\)01090-8](http://doi.org/10.1016/s0006-291x(03)01090-8)
- Kaliszewski, P., & Zoładek, T. (2008). The role of Rsp5 ubiquitin ligase in regulation of diverse processes in yeast cells. *Acta Biochimica Polonica*, 55(4), 649–62. Retrieved from <http://www.ncbi.nlm.nih.gov/pubmed/19039336>
- Kamada, K. (2012). The Eukaryotic Replisome: a Guide to Protein Structure and Function. *Subcellular Biochemistry*, 62, 135–156. <http://doi.org/10.1007/978-94-007-4572-8>
- Kamińska, J., Gajewska, B., Hopper, A. K., & Zoładek, T. (2002). Rsp5p, a new link between the actin cytoskeleton and endocytosis in the yeast *Saccharomyces cerevisiae*. *Molecular and Cellular Biology*, 22(20), 6946–8. <http://doi.org/10.1128/MCB.22.20.6946>
- Katou, Y., Kanoh, Y., Bando, M., Noguchi, H., Tanaka, H., Ashikari, T., ... Shirahige, K. (2003). S-phase checkpoint proteins Tof1 and Mrc1 form a stable replication-pausing complex. *Nature*, 424(6952), 1078–1083. <http://doi.org/10.1038/nature01900>
- Kee, Y., Lyon, N., & Huibregtse, J. M. (2005). The Rsp5 ubiquitin ligase is coupled to and antagonized by the Ubp2 deubiquitinating enzyme. *The EMBO Journal*, 24(13), 2414–2424. <http://doi.org/10.1038/sj.emboj.7600710>
- Kobayashi, T., & Kobayashi, T. (2003). The Replication Fork Barrier Site Forms a Unique Structure with Fob1p and Inhibits the Replication Fork The Replication Fork Barrier Site Forms a Unique Structure with Fob1p and Inhibits the Replication Fork, 23(24), 9178–9188. <http://doi.org/10.1128/MCB.23.24.9178>
- Kogut, I., Wang, J., Guacci, V., Mistry, R. K., & Megee, P. C. (2009). The Scc2/Scc4 cohesin loader determines the distribution of cohesin on budding yeast chromosomes. *Genes and Development*, 23(19), 2345–2357. <http://doi.org/10.1101/gad.1819409>
- Kolas, N. K., Chapman, J. R., Nakada, S., Ylanko, J., Chahwan, R., Sweeney, F. D., ... Durocher, D. (2007). Orchestration of the DNA-damage response by the RNF8 ubiquitin ligase. *Science (New York, N.Y.)*, 318(5856), 1637–1640. <http://doi.org/10.1126/science.1150034>
- Komander, D., & Rape, M. (2012). The Ubiquitin Code. *Annual Review of Biochemistry*, 81(1), 203–229. <http://doi.org/10.1146/annurev-biochem-060310-170328>
- Kueng, S., Hegemann, B., Peters, B. H., Lipp, J. J., Schleiffer, A., Mechtler, K., & Peters, J. M. (2006). Wapl Controls the Dynamic Association of Cohesin with Chromatin. *Cell*, 127(5), 955–967. <http://doi.org/10.1016/j.cell.2006.09.040>
- Kulemzina, I., Schumacher, M. R., Verma, V., Reiter, J., Metzler, J., Failla, A. V., ... Ivanov, D. (2012). Cohesin Rings Devoid of Scc3 and Pds5 Maintain Their Stable Association with the DNA. *PLoS Genetics*, 8(8). <http://doi.org/10.1371/journal.pgen.1002856>
- Labib, K. (2010). Howdo Cdc7 and cyclin-dependent kinases trigger the initiation of chromosome replication in eukaryotic cells? *Genes and Development*, 24(12), 1208–1219. <http://doi.org/10.1101/gad.1933010>
- Lam, M. (2010). Proteomic and Molecular Genetic Investigation of Deubiquitinating Enzymes in the Budding Yeast *Saccharomyces cerevisiae*. Retrieved from

- <https://tspace.library.utoronto.ca/handle/1807/26364>
- Lam, M. H. Y., & Emili, A. (2013). Ubp2 regulates Rsp5 ubiquitination activity in vivo and in vitro. *PLoS One*, 8(9), e75372. <http://doi.org/10.1371/journal.pone.0075372>
- Leman, A. R., Noguchi, C., Lee, C. Y., & Noguchi, E. (2010). Human Timeless and Tipin stabilize replication forks and facilitate sister-chromatid cohesion. *Journal of Cell Science*, 123(Pt 5), 660–670. <http://doi.org/10.1242/jcs.057984>
- Leman, A. R., & Noguchi, E. (2012). Local and global functions of Timeless and Tipin in replication fork protection. *Cell Cycle*, 11(21), 3945–3955. <http://doi.org/10.4161/cc.21989>
- Lengronne, A., Katou, Y., Mori, S., Yokobayashi, S., Kelly, G. P., Itoh, T., ... Uhlmann, F. (2004a). Cohesin relocation from sites of chromosomal loading to places of convergent transcription. *Nature*, 430(6999), 573–8. <http://doi.org/10.1038/nature02742>
- Lengronne, A., Katou, Y., Mori, S., Yokobayashi, S., Kelly, G. P., Itoh, T., ... Uhlmann, F. (2004b). Cohesin relocation from sites of chromosomal loading to places of convergent transcription. *Nature*, 430(6999), 573–8. <http://doi.org/10.1038/nature02742>
- Liberi, G., Maffioletti, G., Lucca, C., Chiolo, I., Baryshnikova, A., Cotta-ramusino, C., ... Foiani, M. (2005). Rad51-dependent DNA structures accumulate at damaged replication forks in. *Genes & Development*, 339–350. <http://doi.org/10.1101/gad.322605.3>
- Liu, J., & Krantz, I. D. (2008). Cohesin and Human Disease. *Annual Review of Genomics and Human Genetics*, 9(1), 303–320. <http://doi.org/10.1146/annurev.genom.9.081307.164211>
- Liu, Y., Kao, H.-I., & Bambara, R. a. (2004). Flap endonuclease 1: a central component of DNA metabolism. *Annual Review of Biochemistry*, 73, 589–615. <http://doi.org/10.1146/annurev.biochem.73.012803.092453>
- Longtine, M. S., McKenzie, A., Demarini, D. J., Shah, N. G., Wach, A., Brachat, A., ... Pringle, J. R. (1998). Additional modules for versatile and economical PCR-based gene deletion and modification in *Saccharomyces cerevisiae*. *Yeast*, 14(10), 953–961. [http://doi.org/10.1002/\(SICI\)1097-0061\(199807\)14:10<953::AID-YEA293>3.0.CO;2-U](http://doi.org/10.1002/(SICI)1097-0061(199807)14:10<953::AID-YEA293>3.0.CO;2-U)
- Lopes, M., Cotta-Ramusino, C., Pelliccioli, a, Liberi, G., Plevani, P., Muzi-Falconi, M., ... Foiani, M. (2001). The DNA replication checkpoint response stabilizes stalled replication forks. *Nature*, 412(6846), 557–61. <http://doi.org/10.1038/35087613>
- Lou, H., Komata, M., Katou, Y., Guan, Z., Reis, C. C., Budd, M., ... Campbell, J. L. (2008). Mrc1 and DNA Polymerase ?? Function Together in Linking DNA Replication and the S Phase Checkpoint. *Molecular Cell*, 32(1), 106–117. <http://doi.org/10.1016/j.molcel.2008.08.020>
- Lucca, C., Vanoli, F., Cotta-Ramusino, C., Pelliccioli, A., Liberi, G., Haber, J., & Foiani, M. (2004). Checkpoint-mediated control of replisome-fork association and signalling in response to replication pausing. *Oncogene*, 23(6), 1206–1213. <http://doi.org/10.1038/sj.onc.1207199>
- Macias, M. J., Hyvönen, M., Baraldi, E., Schultz, J., Sudol, M., Saraste, M., & Oschkinat, H. (1996). Structure of the WW domain of a kinase-associated protein complexed with a proline-rich peptide. *Nature*. <http://doi.org/10.1038/382646a0>

- Maculins, T., Nkosi, P. J., Nishikawa, H., & Labib, K. (2015). Tethering of SCF<sup>Dia2</sup> to the Replisome Promotes Efficient Ubiquitylation and Disassembly of the CMG Helicase. *Current Biology*, 25(17), 2254–2259. <http://doi.org/10.1016/j.cub.2015.07.012>
- Maiorano, D., Lemai, J., & Me, M. (2000). Stepwise Regulated Chromatin Assembly of MCM2 – 7 Proteins \*. *Genetics*, 155(12), 8426–8431.
- Maric, M., Maculins, T., De Piccoli, G., & Labib, K. (2014). Cdc48 and a ubiquitin ligase drive disassembly of the CMG helicase at the end of DNA replication. *Science*, 346(6208), 1253596–1253596. <http://doi.org/10.1126/science.1253596>
- Marston, A. L. (2014a). Chromosome segregation in budding yeast: Sister chromatid cohesion and related mechanisms. *Genetics*, 196(1), 31–63. <http://doi.org/10.1534/genetics.112.145144>
- Marston, A. L. (2014b). Chromosome segregation in budding yeast: sister chromatid cohesion and related mechanisms. *Genetics*, 196(1), 31–63. <http://doi.org/10.1534/genetics.112.145144>
- Mayer, M. L., Pot, I., Chang, M., Xu, H., Aneliunas, V., Kwok, T., ... Hieter, P. (2004). Identification of Protein Complexes Required for Efficient Sister Chromatid Cohesion. *Molecular Biology of the Cell*, 15(April), 1736–1745.
- McGlynn, P., Savery, N. J., & Dillingham, M. S. (2012). The conflict between DNA replication and transcription. *Molecular Microbiology*, 85(1), 12–20. <http://doi.org/10.1111/j.1365-2958.2012.08102.x>
- McIntyre, J., & Woodgate, R. (2015). Regulation of translesion DNA synthesis: Posttranslational modification of lysine residues in key proteins. *DNA Repair*, 29, 166–179. <http://doi.org/10.1016/j.dnarep.2015.02.011>
- McLellan, J. L., O’Neil, N. J., Barrett, I., Ferree, E., van Pel, D. M., Ushey, K., ... Hieter, P. (2012). Synthetic lethality of cohesins with PARPs and replication fork mediators. *PLoS Genetics*, 8(3). <http://doi.org/10.1371/journal.pgen.1002574>
- Meerang, M., Ritz, D., Paliwal, S., Garajova, Z., Bosshard, M., Mailand, N., ... Ramadan, K. (2011). The ubiquitin-selective segregase VCP/p97 orchestrates the response to DNA double-strand breaks. *Nature Cell Biology*, 13(11), 1376–1382. <http://doi.org/10.1038/ncb2367>
- Mohanty, B. K., & Bastia, D. (2004). Binding of the Replication Terminator Protein Fob1p to the Ter Sites of Yeast Causes Polar Fork Arrest. *Journal of Biological Chemistry*, 279(3), 1932–1941. <http://doi.org/10.1074/jbc.M309078200>
- Mouysset, J., Deichsel, A., Moser, S., Hoegge, C., Hyman, A. a, Gartner, A., & Hoppe, T. (2008). Cell cycle progression requires the CDC-48/UDF-1/NPL-4 complex for efficient DNA replication. *Proceedings of the National Academy of Sciences of the United States of America*, 105(35), 12879–12884. <http://doi.org/10.1073/pnas.0805944105>
- Mozlin, A. M., Fung, C. W., & Symington, L. S. (2008). Role of the *Saccharomyces cerevisiae* Rad51 paralogs in sister chromatid recombination. *Genetics*, 178(1), 113–126. <http://doi.org/10.1534/genetics.107.082677>
- Mozlin, A. M., Fung, C. W., & Symington, L. S. (2008). Role of the *Saccharomyces cerevisiae* Rad51 paralogs in sister chromatid recombination. *Genetics*, 178(1), 113–125. <http://doi.org/10.1534/genetics.107.082677>
- Müller, C. a, Hawkins, M., Retkute, R., Malla, S., Wilson, R., Blythe, M. J., ... Nieduszynski, C. a. (2014). The dynamics of genome replication using deep

- sequencing. *Nucleic Acids Research*, 42(1), e3. <http://doi.org/10.1093/nar/gkt878>
- Nasheuer, H.-P., Smith, R., Bauerschmidt, C., Grosse, F., & Weisshart, K. (2002). Initiation of eukaryotic DNA replication: Regulation and mechanisms. *Progress in Nucleic Acid Research and Molecular Biology*, 72, 41–94. [http://doi.org/10.1016/S0079-6603\(02\)72067-9](http://doi.org/10.1016/S0079-6603(02)72067-9)
- Nasmyth, K., & Haering, C. H. (2009). Cohesin: Its Roles and Mechanisms. *Annual Review of Genetics*, 43, 525–558. <http://doi.org/10.1146/annurev-genet-102108-134233>
- Nedelcheva-Veleva, M. N., Krastev, D. B., & Stoynov, S. S. (2006). Coordination of DNA synthesis and replicative unwinding by the S-phase checkpoint pathways. *Nucleic Acids Research*, 34(15), 4138–4146. <http://doi.org/10.1093/nar/gkl528>
- Nedelcheva, M. N., Roguev, A., Dolapchiev, L. B., Shevchenko, A., Taskov, H. B., Shevchenko, A., ... Stoynov, S. S. (2005). Uncoupling of unwinding from DNA synthesis implies regulation of MCM helicase by Tof1/Mrc1/Csm3 checkpoint complex. *Journal of Molecular Biology*, 347(3), 509–521. <http://doi.org/10.1016/j.jmb.2005.01.041>
- Nie, M., Aslanian, A., Prudden, J., Heideker, J., Vashisht, A. A., Wohlschlegel, J. A., ... Boddy, M. N. (2012). Dual recruitment of Cdc48 (p97)-Ufd1-Npl4 ubiquitin-selective segregase by small ubiquitin-like modifier protein (SUMO) and ubiquitin in SUMO-targeted ubiquitin ligase-mediated genome stability functions. *Journal of Biological Chemistry*, 287(35), 29610–29619. <http://doi.org/10.1074/jbc.M112.379768>
- Nishi, R., Wijnhoven, P., le Sage, C., Tjeertes, J., Galanty, Y., Forment, J. V., ... Jackson, S. P. (2014). Systematic characterization of deubiquitylating enzymes for roles in maintaining genome integrity. *Nature Cell Biology*, 16(10), 1016–26, 1–8. <http://doi.org/10.1038/ncb3028>
- Nishitani, H., Lygerou, Z., Nishimoto, T., & Nurse, P. (2000). The Cdt1 protein is required to license DNA for replication in fission yeast. *Nature*, 404(6778), 625–628. <http://doi.org/10.1038/35007110>
- Noguchi, E., Noguchi, C., McDonald, W. H., Yates, J. R., & Russell, P. (2004). Swi1 and Swi3 are components of a replication fork protection complex in fission yeast. *Molecular and Cellular Biology*, 24(19), 8342–55. <http://doi.org/10.1128/MCB.24.19.8342-8355.2004>
- Novoselova, T. V., Zahira, K., Rose, R. S., & Sullivan, J. A. (2012). Bul proteins, a nonredundant, antagonistic family of ubiquitin ligase regulatory proteins. *Eukaryot Cell*, 11(4), 463–470. <http://doi.org/10.1128/EC.00009-12>
- Nyberg, K. a, Michelson, R. J., Putnam, C. W., & Weinert, T. a. (2002). Toward maintaining the genome: DNA damage and replication checkpoints. *Annual Review of Genetics*, 36, 617–656. <http://doi.org/10.1146/annurev.genet.36.060402.113540>
- O'Donnell, a. F. (2012). The Running of the Bulls: Control of Permease Trafficking by - Arrestins Bul1 and Bul2. *Molecular and Cellular Biology*, 32(22), 4506–4509. <http://doi.org/10.1128/MCB.01176-12>
- Osborn, A. J., & Elledge, S. J. (2003). Mrc1 is a replication fork component whose phosphorylation in response to DNA replication stress activates Rad53. *Genes and Development*, 17(14), 1755–1767. <http://doi.org/10.1101/gad.1098303>
- Ossareh-Nazari, B., Bonizec, M., Cohen, M., Dokudovskaya, S., Delalande, F., Schaeffer,

- C., ... Dargemont, C. (2010). Cdc48 and Ufd3, new partners of the ubiquitin protease Ubp3, are required for ribophagy. *EMBO Reports*, *11*(7), 548–54. <http://doi.org/10.1038/embor.2010.74>
- Paciotti, V., Clerici, M., Scotti, M., Lucchini, G., & Longhese, M. P. (2001). Characterization of mec1 kinase-deficient mutants and of new hypomorphic mec1 alleles impairing subsets of the DNA damage response pathway. *Molecular and Cellular Biology*, *21*(12), 3913–3925. <http://doi.org/10.1128/MCB.21.12.3913-3925.2001>
- Panier, S., Ichijima, Y., Fradet-Turcotte, A., Leung, C. C. Y., Kaustov, L., Arrowsmith, C. H., & Durocher, D. (2012). Tandem Protein Interaction Modules Organize the Ubiquitin-Dependent Response to DNA Double-Strand Breaks. *Molecular Cell*, *47*(3), 383–395. <http://doi.org/10.1016/j.molcel.2012.05.045>
- Panizza, S., Tanaka, T., Hochwagen, A., Eisenhaber, F., & Nasmyth, K. (2000). Pds5 cooperates with cohesin in maintaining sister chromatid cohesion. *Current Biology : CB*, *10*(24), 1557–1564. [http://doi.org/10.1016/S0960-9822\(00\)00854-X](http://doi.org/10.1016/S0960-9822(00)00854-X)
- Paulovich, a G., & Hartwell, L. H. (1995). A checkpoint regulates the rate of progression through S phase in *S. cerevisiae* in response to DNA damage. *Cell*, *82*(5), 841–7. Retrieved from <http://www.ncbi.nlm.nih.gov/pubmed/7671311>
- Pelliccioli, A., & Foiani, M. (2005). Signal transduction: how rad53 kinase is activated. *Curr Biol*, *15*(18), R769–71. <http://doi.org/10.1016/j.cub.2005.08.057>
- Pickart, C. M. (2001). Ubiquitin enters the new millennium: Meeting review. *Molecular Cell*, *8*(3), 499–504. [http://doi.org/10.1016/S1097-2765\(01\)00347-1](http://doi.org/10.1016/S1097-2765(01)00347-1)
- Prado, F., & Aguilera, A. (2005). Impairment of replication fork progression mediates RNA polII transcription-associated recombination. *The EMBO Journal*, *24*(6), 1267–1276. <http://doi.org/10.1038/sj.emboj.7600602>
- Press, D. (2013). Genetic basis of cohesinopathies, 15–23.
- Priego Moreno, S., Bailey, R., Campion, N., Herron, S., & Gambus, a. (2014). Polyubiquitylation drives replisome disassembly at the termination of DNA replication. *Science*, *346*(6208), 477–481. <http://doi.org/10.1126/science.1253585>
- Rabinovich, E., Kerem, A., Fröhlich, K.-U., Diamant, N., & Bar-Nun, S. (2002). AAA-ATPase p97/Cdc48p, a cytosolic chaperone required for endoplasmic reticulum-associated protein degradation. *Molecular and Cellular Biology*, *22*(2), 626–34. <http://doi.org/10.1128/MCB.22.2.626>
- Raghuraman, M. K., Winzeler, E. A., Collingwood, D., Hunt, S., Wodicka, L., Conway, A., ... Fangman, W. L. (2001). Replication dynamics of the yeast genome. *Science*, *294*(5540), 115–121. <http://doi.org/10.1126/science.294.5540.115>
- Randell, J. C. W., Fan, A., Chan, C., Francis, L. I., Heller, R. C., Galani, K., & Bell, S. P. (2010). Mec1 Is One of Multiple Kinases that Prime the Mcm2-7 Helicase for Phosphorylation by Cdc7. *Molecular Cell*, *40*(3), 353–363. <http://doi.org/10.1016/j.molcel.2010.10.017>
- Ritz, D., Vuk, M., Kirchner, P., Bug, M., Schütz, S., Bremer, S., ... Meyer, H. (2011). NIH Public Access, *13*(9), 1116–1123. <http://doi.org/10.1038/ncb2301.Endolysosomal>
- Rodriguez, J., & Tsukiyama, T. (2013). ATR-like kinase Mec1 facilitates both chromatin accessibility at DNA replication forks and replication fork progression during replication stress. *Genes Dev*, *27*(1), 74–86. <http://doi.org/10.1101/gad.202978.112>

- Roig, M. B., Löwe, J., Chan, K. L., Beckouët, F., Metson, J., & Nasmyth, K. (2014). Structure and function of cohesin's Scc3/SA regulatory subunit. *FEBS Letters*, *588*(20), 3692–3702. <http://doi.org/10.1016/j.febslet.2014.08.015>
- Rotin, D., & Kumar, S. (2009). Physiological functions of the HECT family of ubiquitin ligases. *Nature Reviews. Molecular Cell Biology*, *10*(6), 398–409. <http://doi.org/10.1038/nrm2690>
- Rowland, B. D., Roig, M. B., Nishino, T., Kurze, A., Uluocak, P., Mishra, A., ... Nasmyth, K. (2009). Building Sister Chromatid Cohesion: Smc3 Acetylation Counteracts an Antiestablishment Activity. *Molecular Cell*, *33*(6), 763–774. <http://doi.org/10.1016/j.molcel.2009.02.028>
- Rudra, S., & Skibbens, R. V. (2012). Sister chromatid cohesion establishment occurs in concert with lagging strand synthesis. *Cell Cycle*, *11*(11), 2114–2121. <http://doi.org/10.4161/cc.20547>
- Ryu, M. J., Kim, B. J., Lee, J. W., Lee, M. W., Choi, H. K., & Kim, S. T. (2006). Direct interaction between cohesin complex and DNA replication machinery. *Biochemical and Biophysical Research Communications*, *341*(3), 770–775. <http://doi.org/10.1016/j.bbrc.2006.01.029>
- Shirahige, K., Hori, Y., Shiraishi, K., Yamashita, M., Takahashi, K., Obuse, C., ... Yoshikawa, H. (1998). Regulation of DNA-replication origins during cell-cycle progression. *Nature*, *395*(6702), 618–21. <http://doi.org/10.1038/27007>
- Skibbens, R. V. (2009). Establishment of Sister Chromatid Cohesion. *Current Biology*, *19*(24), R1126–R1132. <http://doi.org/10.1016/j.cub.2009.10.067>
- Smolka, M. B., Albuquerque, C. P., Chen, S. H., & Zhou, H. (2007). Proteome-wide identification of in vivo targets of DNA damage checkpoint kinases. *Proc Natl Acad Sci U S A*, *104*(25), 10364–10369. <http://doi.org/10.1073/pnas.0701622104>
- Sogo, J. M., Lopes, M., & Foiani, M. (2002). Fork reversal and ssDNA accumulation at stalled replication forks owing to checkpoint defects. *Science*, *297*(5581), 599–602. <http://doi.org/10.1126/science.1074023>
- Sogo, J. M., Lopes, M., & Foiani, M. (2002). Fork Reversal and ssDNA Accumulation at Stalled Replication Forks Owing to Checkpoint Defects. *Science*, *297* (5581), 599–602. <http://doi.org/10.1126/science.1074023>
- Sommariva, E., Pellny, T. K., Karahan, N., Kumar, S., Huberman, J. A., & Dalgaard, J. Z. (2005). Schizosaccharomyces pombe Swi1, Swi3, and Hsk1 are components of a novel S-phase response pathway to alkylation damage. *Molecular and Cellular Biology*, *25*(7), 2770–84. <http://doi.org/10.1128/MCB.25.7.2770-2784.2005>
- Stelter, P., & Ulrich, H. D. (2003). Control of spontaneous and damage-induced mutagenesis by SUMO and ubiquitin conjugation. *Nature*, *425*(6954), 188–91. <http://doi.org/10.1038/nature01965>
- Stinchcomb, D. T., Thomas, M., Kelly, J., Selker, E., & Davis, R. W. (1980). Eukaryotic DNA segments capable of autonomous replication in yeast. *Proceedings of the National Academy of Sciences of the United States of America*, *77*(8), 4559–63. <http://doi.org/DOI 10.1073/pnas.77.8.4559>
- Sutani, T., Kawaguchi, T., Kanno, R., Itoh, T., & Shirahige, K. (2009). Budding Yeast Wpl1(Rad61)-Pds5 Complex Counteracts Sister Chromatid Cohesion-Establishing Reaction. *Current Biology*, *19*(6), 492–497. <http://doi.org/10.1016/j.cub.2009.01.062>
- Szyjka, S. J., Viggiani, C. J., & Aparicio, O. M. (2005). Mrc1 is required for normal

- progression of replication forks throughout chromatin in *S. cerevisiae*. *Molecular Cell*, *19*(5), 691–697. <http://doi.org/10.1016/j.molcel.2005.06.037>
- Tanaka, K., Hao, Z., Kai, M., & Okayama, H. (2001). Establishment and maintenance of sister chromatid cohesion in *S. cerevisiae* yeast by a unique mechanism. *Molecular Cell*, *20*(20), 5779–5790.
- Tercero, A., Longhese, M. P., Diffley, J. F. X., & Milano-bicocca, S. (2003). A Central Role for DNA Replication Forks. *Molecular Cell*, *11*, 1323–1336.
- Tercero, J. a., & Diffley, J. F. (2001). Regulation of DNA replication fork progression through damaged DNA by the Mec1/Rad53 checkpoint. *Nature*, *412*(0028-0836; 6846), 553–557. <http://doi.org/10.1038/35087607>
- Thomas, B. J., & Rothstein, R. (1989). The genetic control of direct-repeat recombination in *Saccharomyces*: The effect of rad52 and rad1 on mitotic recombination at GAL10, a transcriptionally regulated gene. *Genetics*, *123*(4), 725–738.
- Tittel-Elmer, M., Lengronne, A., Davidson, M. B., Bacal, J., Francois, P., Hohl, M., ... Cobb, J. A. (2012). Cohesin association to replication sites depends on rad50 and promotes fork restart. *Mol Cell*, *48*(1), 98–108. <http://doi.org/10.1016/j.molcel.2012.07.004>
- Tourrière, H., Versini, G., Cerdón-Preciado, V., Alabert, C., & Pasero, P. (2005). Mrc1 and Tof1 promote replication fork progression and recovery independently of Rad53. *Molecular Cell*, *19*(5), 699–706. <http://doi.org/10.1016/j.molcel.2005.07.028>
- Traven, A., & Heierhorst, J. (2005). SQ/TQ cluster domains: Concentrated ATM/ATR kinase phosphorylation site regions in DNA-damage-response proteins. *BioEssays*, *27*(4), 397–407. <http://doi.org/10.1002/bies.20204>
- Tresse, E., Salomons, F. A., Vesa, J., Bott, L. C., Kimonis, V., Yao, T. P., ... Taylor, J. P. (2010). VCP/p97 is essential for maturation of ubiquitin-containing autophagosomes and this function is impaired by mutations that cause IBMPFD. *Autophagy*, *6*(2), 217–227. <http://doi.org/10.4161/auto.6.2.11014>
- Uhlmann, F., Lottspeich, F., & Nasmyth, K. (1999). Sister-chromatid separation at anaphase onset is promoted by cleavage of the cohesin subunit Scc1. *Nature*, *400*(6739), 37–42. <http://doi.org/10.1038/21831>
- Uhlmann, F., Wernic, D., Poupard, M. a, Koonin, E. V., & Nasmyth, K. (2000). Cleavage of cohesin by the CD clan protease separin triggers anaphase in yeast. *Cell*, *103*(3), 375–386. [http://doi.org/10.1016/S0092-8674\(00\)00130-6](http://doi.org/10.1016/S0092-8674(00)00130-6)
- Unal, E., Heidinger-Pauli, J. M., Kim, W., Guacci, V., Onn, I., Gygi, S. P., & Koshland, D. E. (2008). A molecular determinant for the establishment of sister chromatid cohesion. *Science (New York, N.Y.)*, *321*(5888), 566–9. <http://doi.org/10.1126/science.1157880>
- Ünal, E., Heidinger-Pauli, J. M., & Koshland, D. (2007). DNA Double-Strand Breaks Trigger Genome-Wide Sister-Chromatid Cohesion Through Eco1 (Ctf7). *Science*, *317*(July), 245–249.
- Vega, I. A. De, Martín, Y., & Smits, V. A. J. (2014). Usp7 controls chk1 protein stability by direct deubiquitination. *Cell Cycle*, *13*(24), 3921–3926. <http://doi.org/10.4161/15384101.2014.973324>
- Verma, R., Oania, R., Fang, R., Smith, G. T., & Deshaies, R. J. (2011). Cdc48/p97 mediates UV-dependent turnover of RNA Pol II. *Molecular Cell*, *41*(1), 82–92.

- <http://doi.org/10.1016/j.molcel.2010.12.017>
- Verma, R., Oania, R. S., Kolawa, N. J., & Deshaies, R. J. (2013). Cdc48/p97 promotes degradation of aberrant nascent polypeptides bound to the ribosome. *eLife*, *2013*(2), 1–17. <http://doi.org/10.7554/eLife.00308>
- Wang, G., Yang, J., & Huibregtse, J. M. (1999). Functional domains of the Rsp5 ubiquitin-protein ligase. *Molecular and Cellular Biology*, *19*(1), 342–352.
- Wang, Z., & Christman, M. F. (2001). Replication-related activities establish cohesion between sister chromatids. *Cell Biochemistry and Biophysics*, *35*(3), 289–301. <http://doi.org/10.1385/CBB:35:3:289>
- Watanabe, D., Murai, H., Tanahashi, R., Nakamura, K., Sasaki, T., & Takagi, H. (2015). Cooperative and selective roles of the WW domains of the yeast Nedd4-like ubiquitin ligase Rsp5 in the recognition of the arrestin-like adapters Bul1 and Bul2. *Biochemical and Biophysical Research Communications*, *463*(1-2), 76–81. <http://doi.org/10.1016/j.bbrc.2015.05.025>
- Weinert, T. E. D. A., & Hartwell, L. H. (1988). The RAD9 Gene Controls the Cell Cycle Saccharomyces cerevisiae. *Cell Cycle*, *241*(July), 317–322.
- Weitzer, S., Lehane, C., & Uhlmann, F. (2003). A Model for ATP Hydrolysis-Dependent Binding of Cohesin to DNA. *Current Biology*, *13*(22), 1930–1940. <http://doi.org/10.1016/j.cub.2003.10.030>
- Wellinger, R. E., & Sogo, J. M. (1998). In vivo mapping of nucleosomes using psoralen-DNA crosslinking and primer extension. *Nucleic Acids Research*, *26*(6), 1544–1545. <http://doi.org/10.1093/nar/26.6.1544>
- Wendt, K. S., Yoshida, K., Itoh, T., Bando, M., Koch, B., Schirghuber, E., ... Peters, J.-M. (2008). Cohesin mediates transcriptional insulation by CCCTC-binding factor. *Nature*, *451*(7180), 796–801. <http://doi.org/10.1038/nature06634>
- Williams, B. C., Garrett-Engele, C. M., Li, Z., Williams, E. V., Rosenman, E. D., & Goldberg, M. L. (2003). Two Putative Acetyltransferases, San and Deco, Are Required for Establishing Sister Chromatid Cohesion in Drosophila. *Current Biology*, *13*(23), 2025–2036. <http://doi.org/10.1016/j.cub.2003.11.018>
- Wilson, M. D., Harreman, M., & Svejstrup, J. Q. (2013). Ubiquitylation and degradation of elongating RNA polymerase II: The last resort. *Biochimica et Biophysica Acta - Gene Regulatory Mechanisms*, *1829*(1), 151–157. <http://doi.org/10.1016/j.bbagr.2012.08.002>
- Xu, P., Duong, D. M., Seyfried, N. T., Cheng, D., Xie, Y., Rush, J., ... Peng, J. (2010). NIH Public Access, *137*(1), 133–145. <http://doi.org/10.1016/j.cell.2009.01.041>. Quantitative
- Xu, X., Blackwell, S., Lin, A., Li, F., Qin, Z., & Xiao, W. (2014). Error-free DNA-damage tolerance in Saccharomyces cerevisiae. *Mutation Research - Reviews in Mutation Research*, *764*, 43–50. <http://doi.org/10.1016/j.mrrev.2015.02.001>
- Yakovchuk, P., Protozanova, E., & Frank-Kamenetskii, M. D. (2006). Base-stacking and base-pairing contributions into thermal stability of the DNA double helix. *Nucleic Acids Research*, *34*(2), 564–574. <http://doi.org/10.1093/nar/gkj454>
- Yashiroda, H., Kaida, D., Toh-e, a, & Kikuchi, Y. (1998a). The PY-motif of Bul1 protein is essential for growth of Saccharomyces cerevisiae under various stress conditions. *Gene*, *225*(1-2), 39–46. [http://doi.org/10.1016/S0378-1119\(98\)00535-6](http://doi.org/10.1016/S0378-1119(98)00535-6)
- Yashiroda, H., Kaida, D., Toh-e, a, & Kikuchi, Y. (1998b). The PY-motif of Bul1 protein is essential for growth of Saccharomyces cerevisiae under various stress conditions.

- Gene*, 225(1-2), 39–46. Retrieved from <http://www.ncbi.nlm.nih.gov/pubmed/9931424>
- Yashiroda, H., Oguchi, T., Yasuda, Y., Tohe, A., & Kikuchi, Y. (1996). Bul1, a new-protein that binds to the *rsp5* ubiquitin ligase in *saccharomyces-cerevisiae*. *Molecular and Cellular Biology*, 16(N7), 3255–3263.
- You, Z., Kong, L., & Newport, J. (2002). The role of single-stranded DNA and polymerase  $\alpha$  in establishing the ATR, Hus1 DNA replication checkpoint. *Journal of Biological Chemistry*, 277(30), 27088–27093. <http://doi.org/10.1074/jbc.M204120200>
- Yu, C., Gan, H., Han, J., Zhou, Z. X., Jia, S., Chabes, A., ... Zhang, Z. (2014). Strand-Specific Analysis Shows Protein Binding at Replication Forks and PCNA Unloading from Lagging Strands when Forks Stall. *Molecular Cell*, 56(4), 551–563. <http://doi.org/10.1016/j.molcel.2014.09.017>
- Zegerman, P., & Diffley, J. F. (2009). DNA replication as a target of the DNA damage checkpoint. *DNA Repair (Amst)*, 8(9), 1077–1088. <http://doi.org/10.1016/j.dnarep.2009.04.023>
- Zeman, M. K., & Cimprich, K. a. (2014). Causes and consequences of replication stress. *Nature Cell Biology*, 16(1), 2–9. <http://doi.org/10.1038/ncb2897>
- Zhang, D., Zaugg, K., Mak, T. W., & Elledge, S. J. (2006). A Role for the Deubiquitinating Enzyme USP28 in Control of the DNA-Damage Response. *Cell*, 126(3), 529–542. <http://doi.org/10.1016/j.cell.2006.06.039>
- Zhang, J., Shi, X., Li, Y., Kim, B. J., Jia, J., Huang, Z., ... Qin, J. (2008). Acetylation of Smc3 by Eco1 Is Required for S Phase Sister Chromatid Cohesion in Both Human and Yeast. *Molecular Cell*, 31(1), 143–151. <http://doi.org/10.1016/j.molcel.2008.06.006>
- Zhao, X., Muller, E. G. ., & Rothstein, R. (1998). A Suppressor of Two Essential Checkpoint Genes Identifies a Novel Protein that Negatively Affects dNTP Pools. *Molecular Cell*, 2(3), 329–340. [http://doi.org/10.1016/S1097-2765\(00\)80277-4](http://doi.org/10.1016/S1097-2765(00)80277-4)
- Zhou, B. S., & Elledge, S. J. (2000). Checkpoints in perspective. *Nature*, 408(November), 433–439.
- Zhu, Q., Sharma, N., He, J., Wani, G., & Wani, A. a. (2015). USP7 deubiquitinase promotes ubiquitin-dependent DNA damage signaling by stabilizing RNF168. *Cell Cycle (Georgetown, Tex.)*, 4101(May 2015), 37–41. <http://doi.org/10.1080/15384101.2015.1007785>
- Zou, L., & Elledge, S. J. (2003). Sensing DNA damage through ATRIP recognition of RPA-ssDNA complexes. *Science*, 300(5625), 1542–1548. <http://doi.org/10.1126/science.1083430>